



## 1. GENERAL RECOMMENDATIONS

External venetian blind installation can only be performed by a trained installation team. It is necessary to comply with occupational health and safety regulations, in particular concerning the safety of electrical equipment and work at heights.

Do not attempt to alter or modify the product without authorization; otherwise your product warranty will be void and the product may become a hazard of injury or death. Have all repairs done by a qualified technical service provider of the vendor or its authorized reseller.

### For installation, use:

- If the installation is performed to the reinforced concrete lintel or on a solid brick - use rawplugs  $\varnothing 6 \div 8$  mm.
- If the installation is performed to a wall made of porous materials - use suitable installation systems for this type of walls.
- If the installation is performed to the walls made of cavity brick or aerated concrete, etc. - use plugs for cavity brick.

### Installation conditions:

- For walls - perform an installation to even surfaces of a proper durability, made in accordance with effective regulations of Building Law.
- For metal constructions - perform an installation to materials with a proper thickness of walls joined with one another in accordance with effective rules of metalworking.

### Preparation works:

Unloading, stacking and storage of venetian blinds elements should be carried out with the necessary precautions. The venetian blind on site must be delivered complete, in accordance with the order.

Before starting installation works it is necessary to check:

- quantity and quality of delivered components in accordance with the enclosed specification,
- external dimensions of the blinds,
- width of the jamb opening
- height of the jamb opening
- diagonals of the jamb opening

 *The installation methods of the venetian blinds presented in the manual are only examples.*

## 2. INSTALLATION TOOLS

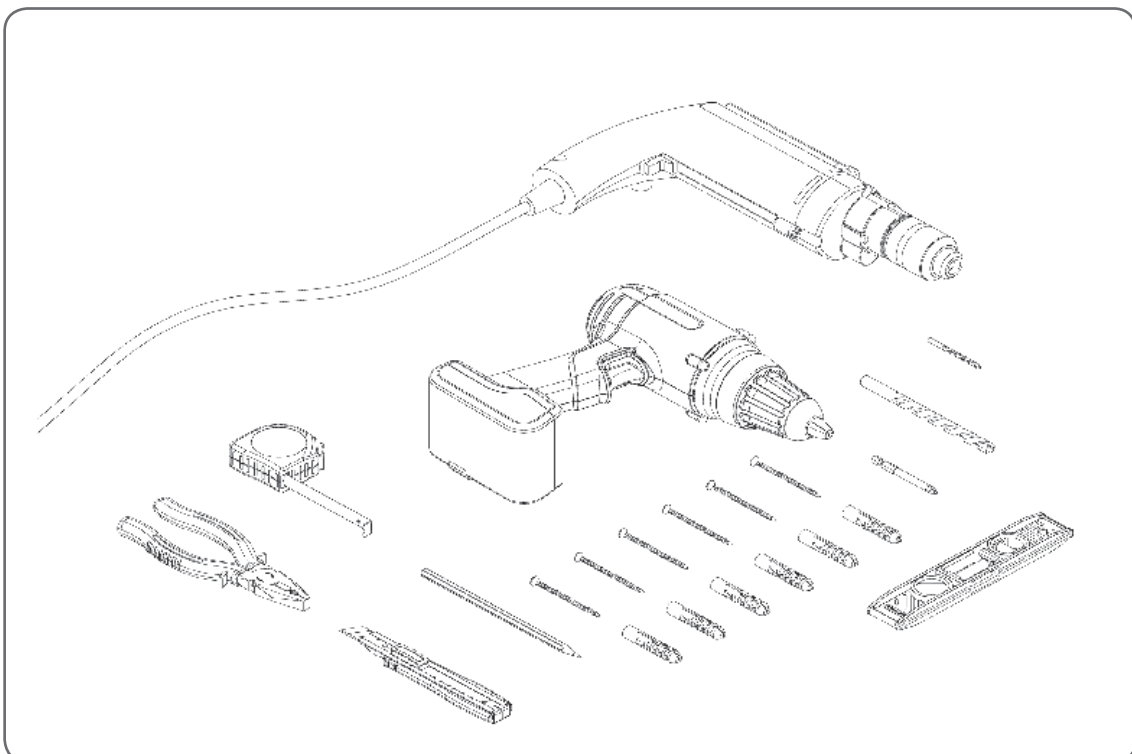

### 3. PRE-ASSEMBLY WORK

#### 3.1. The components of the venetian blind

 Before the installation it is necessary to unpack the item and check its quantity and quality.

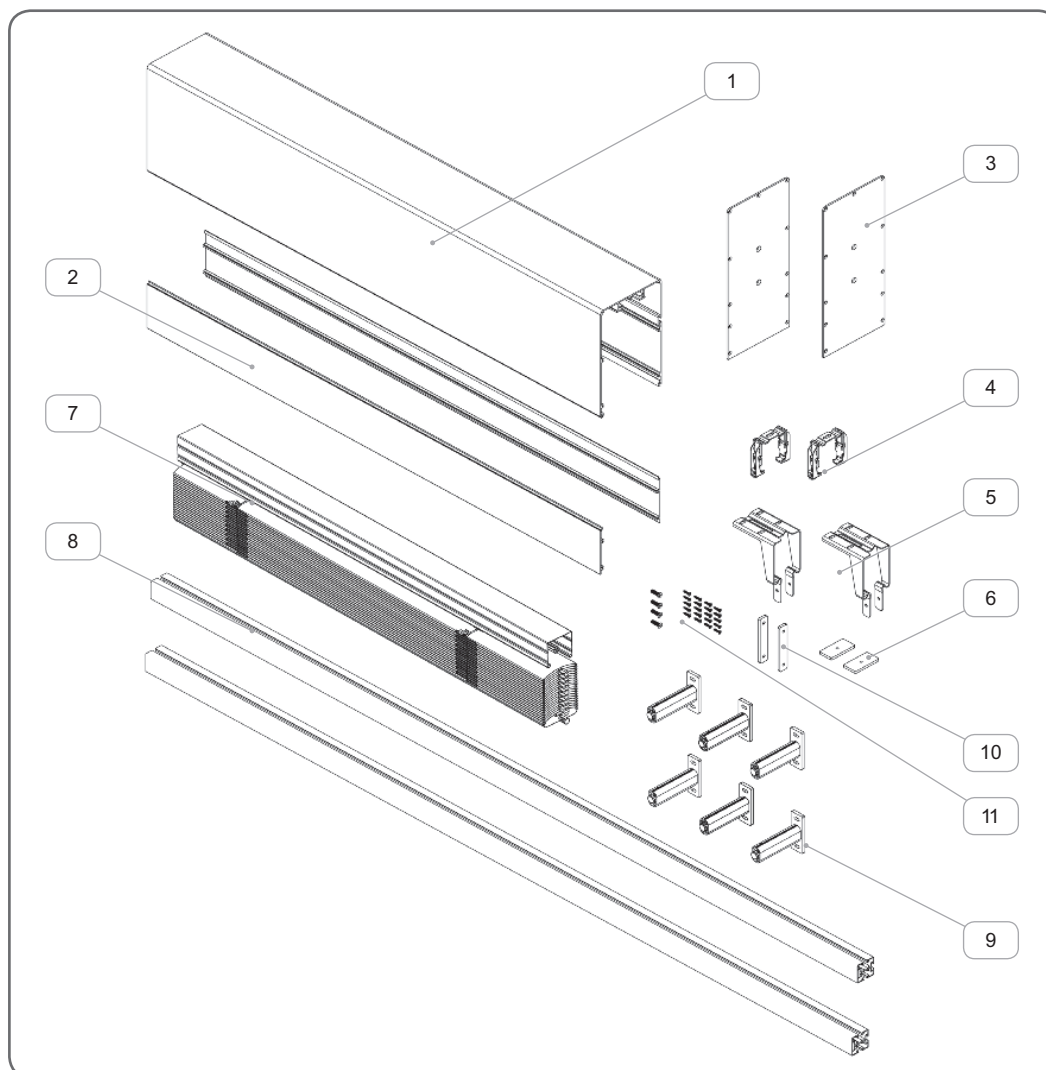

	Name of the component	Catalogue code
1.	Box 240 - square	<b>SZF90/240</b>
2.	Extension of the box	<b>PZF/105, PZF/165</b>
3.	end cap	<b>PB90 SZF/240, PB90 SZF/340, PB SZF/400</b>
4.	Guide rail bracket	<b>US/A, US/B</b>
5.	Self-supporting guide channel handle	<b>USP/1</b>
6.	Rail handle mounting bracket	<b>MUS SZF/1</b>
7.	Package of the venetian blinds	
8.	Guide channels	<b>PPD SZF/2</b>
9.	Guide channel handle	<b>PUT SZF + ZUP SZF/4</b>
10.	Guide channel mount	<b>MPP SZF</b>
11.	Fasteners	

### 3.2. Dimensioning

1. Venetian blind dimensions are determined by dimensions of the window recess.

2. Where:

**S** - WIDTH OF WINDOW

**H** - HEIGHT OF THE WINDOW

**A** - VENETIAN BLIND WIDTH

**B** - BLINDS HEIGHT      **B1** - BOX HEIGHT

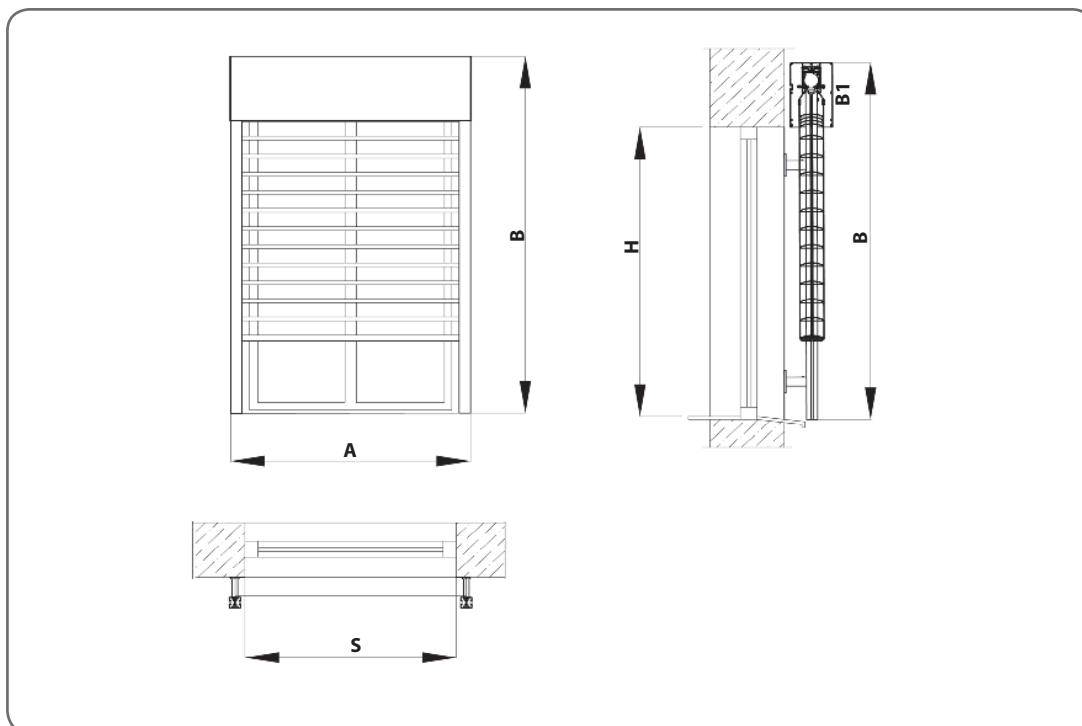

 Check the compliance of the dimensions.

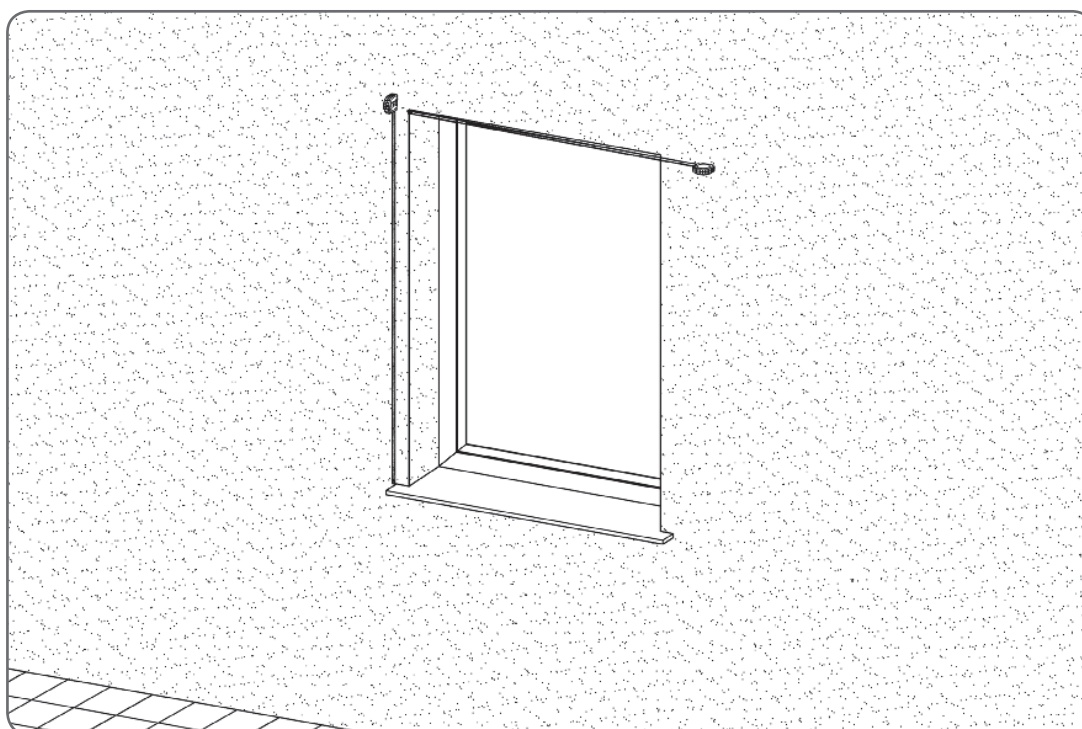



## 4. INSTALLATION SCHEME

### 4.1. Installation of guide channels

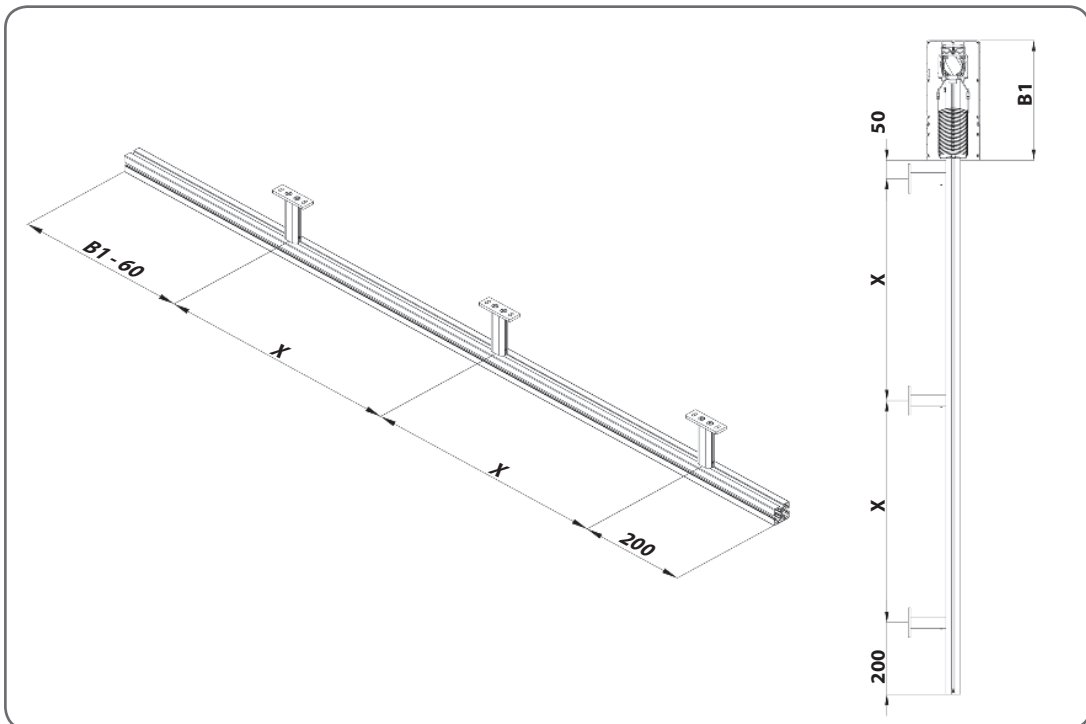
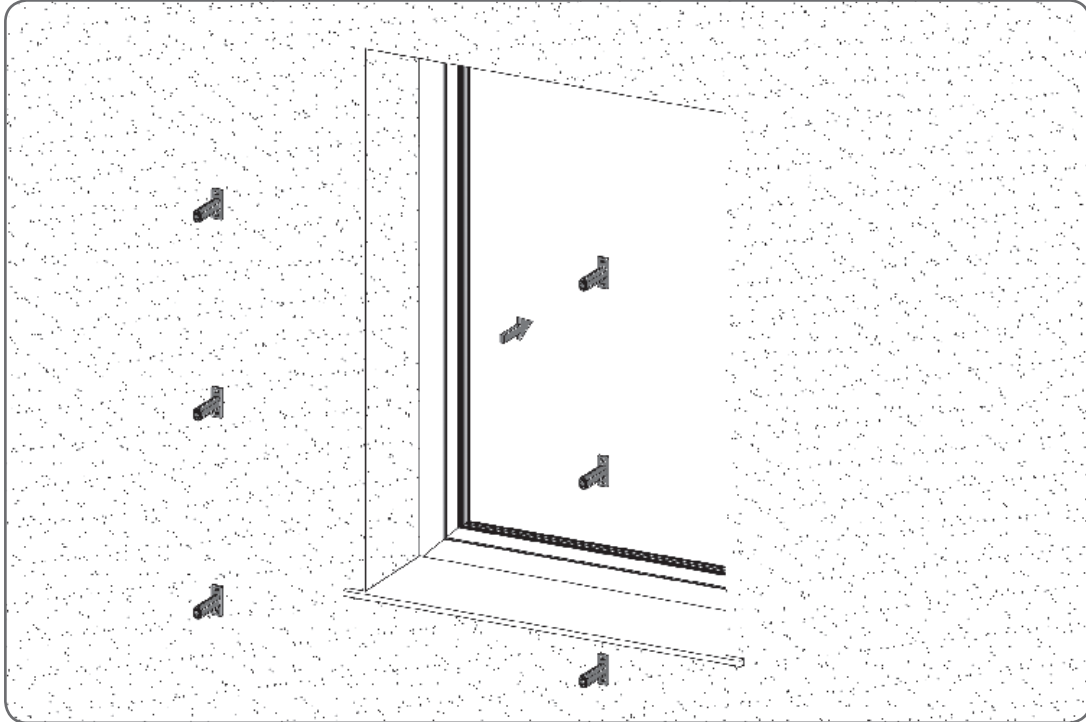

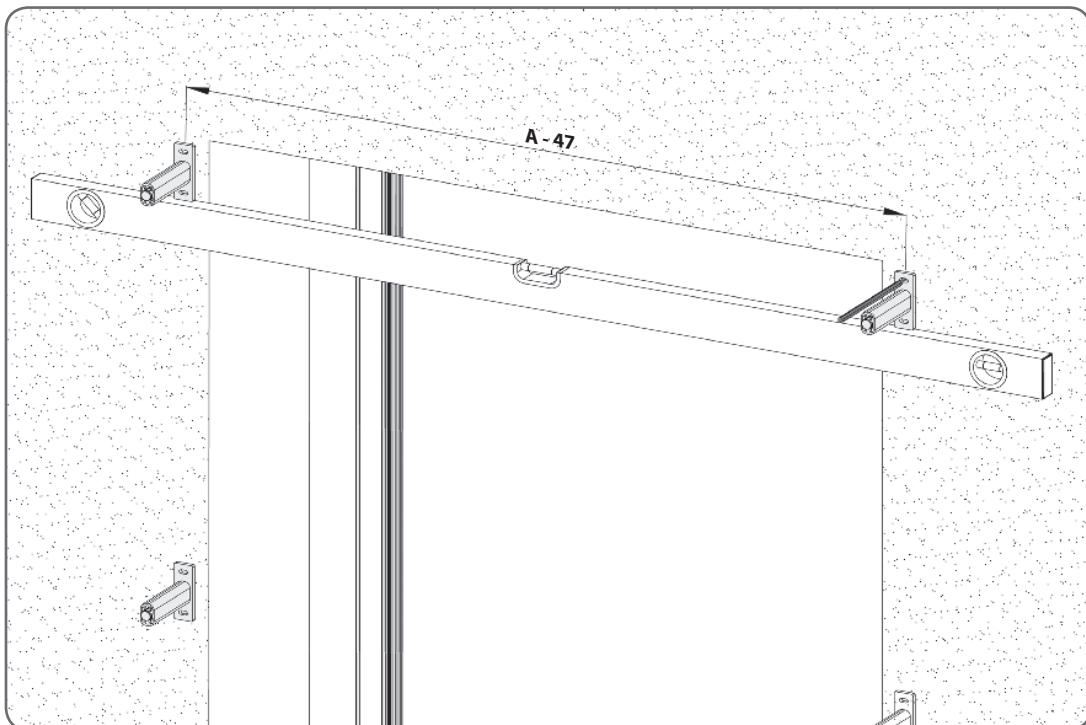
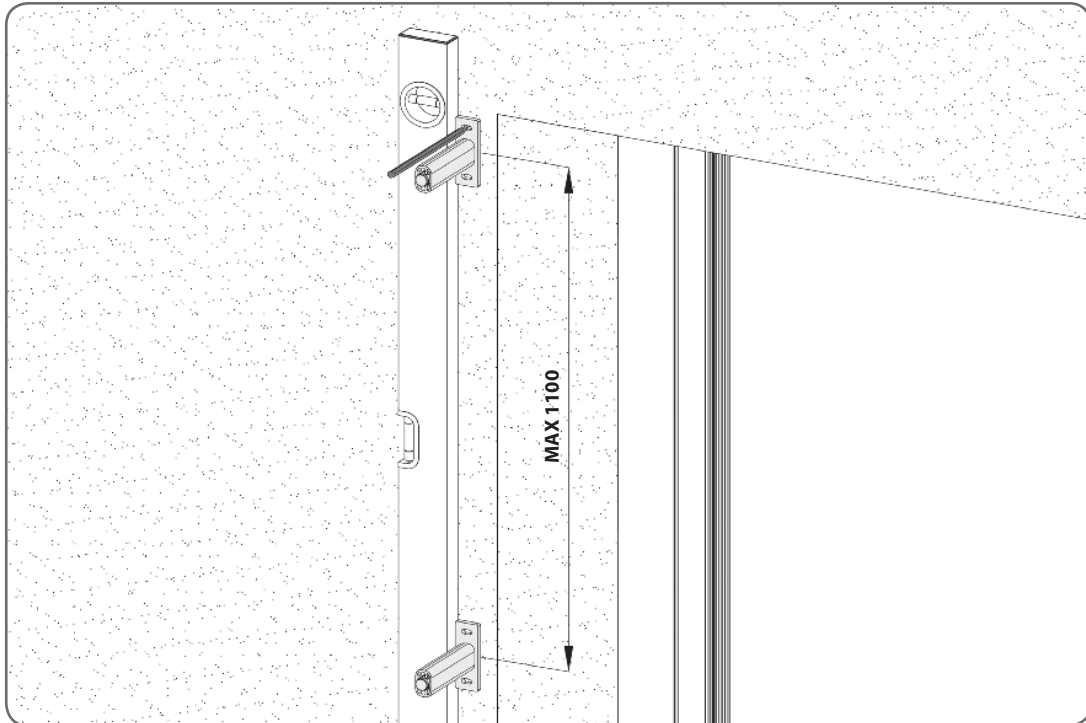

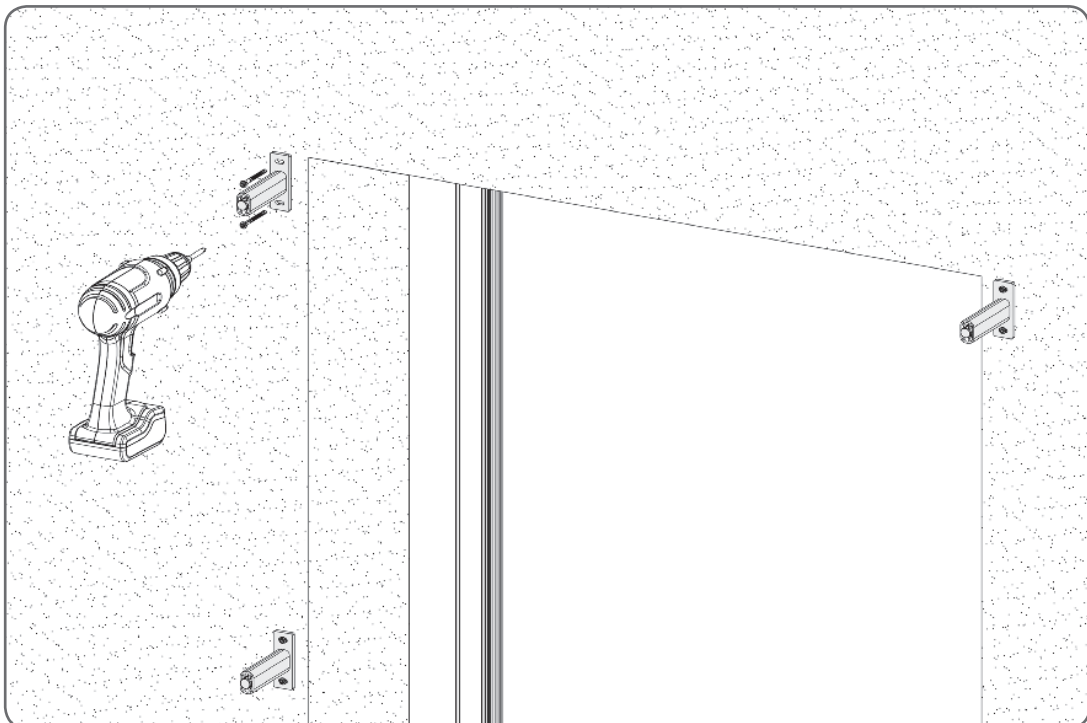
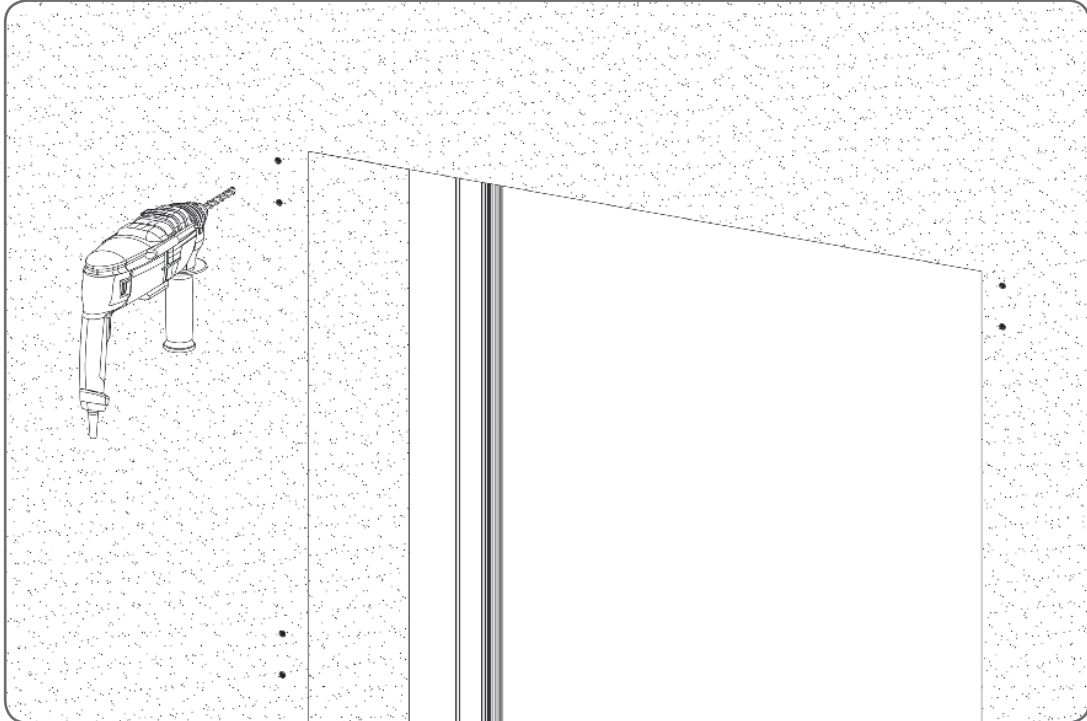

## 4.2. Installation of guide channels

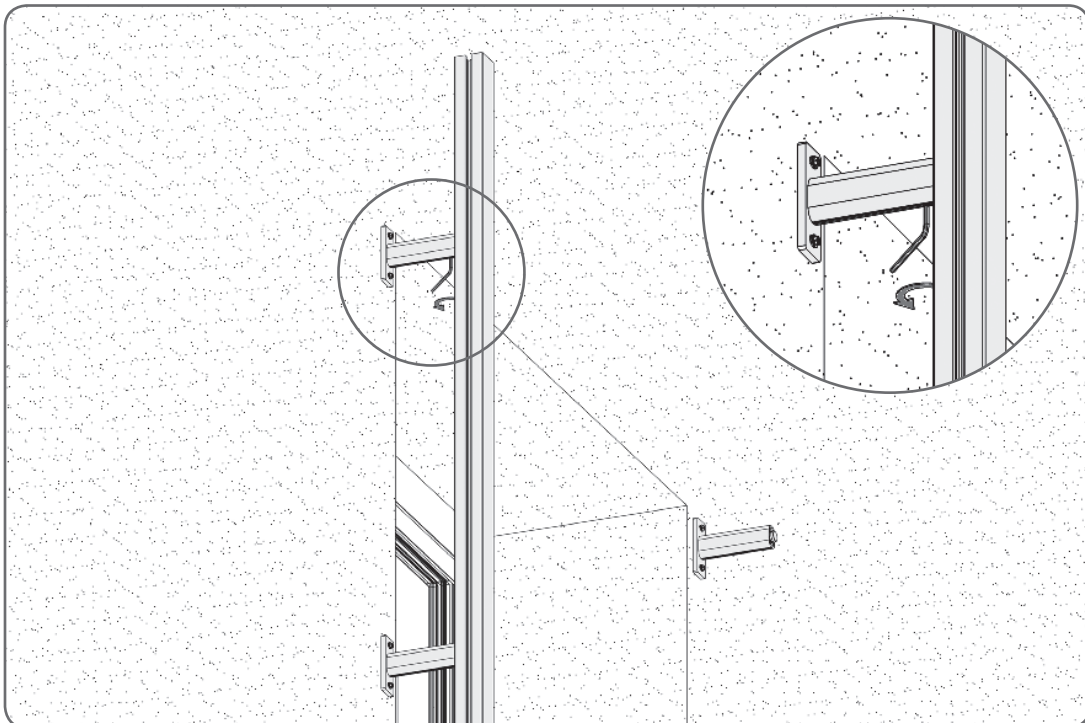
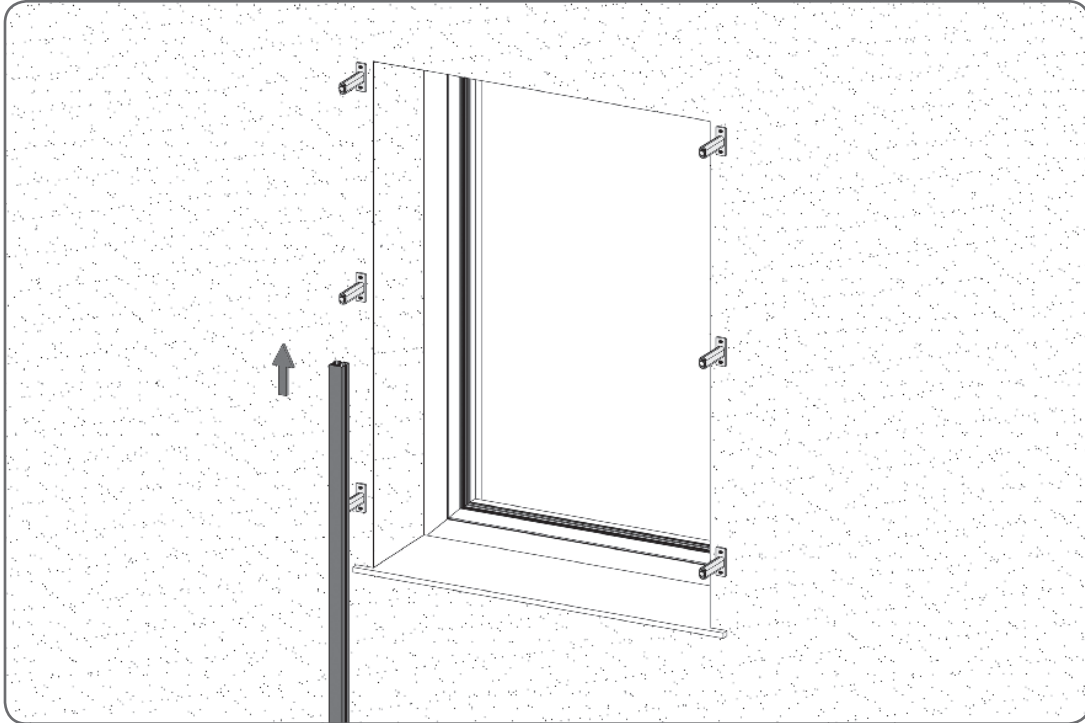

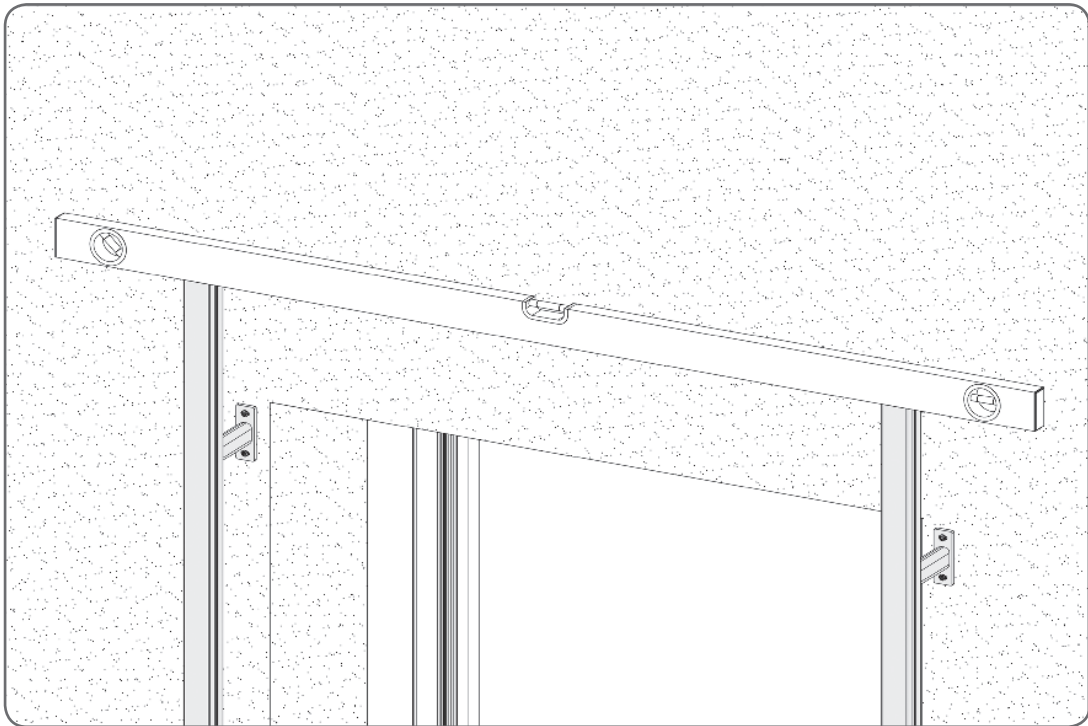
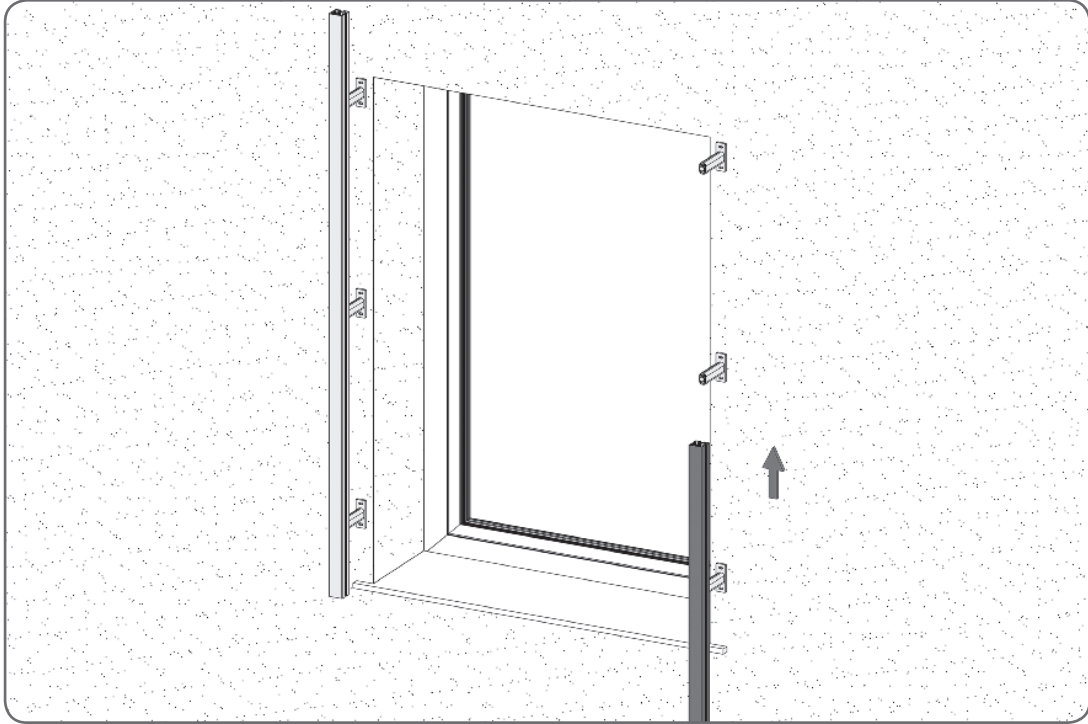

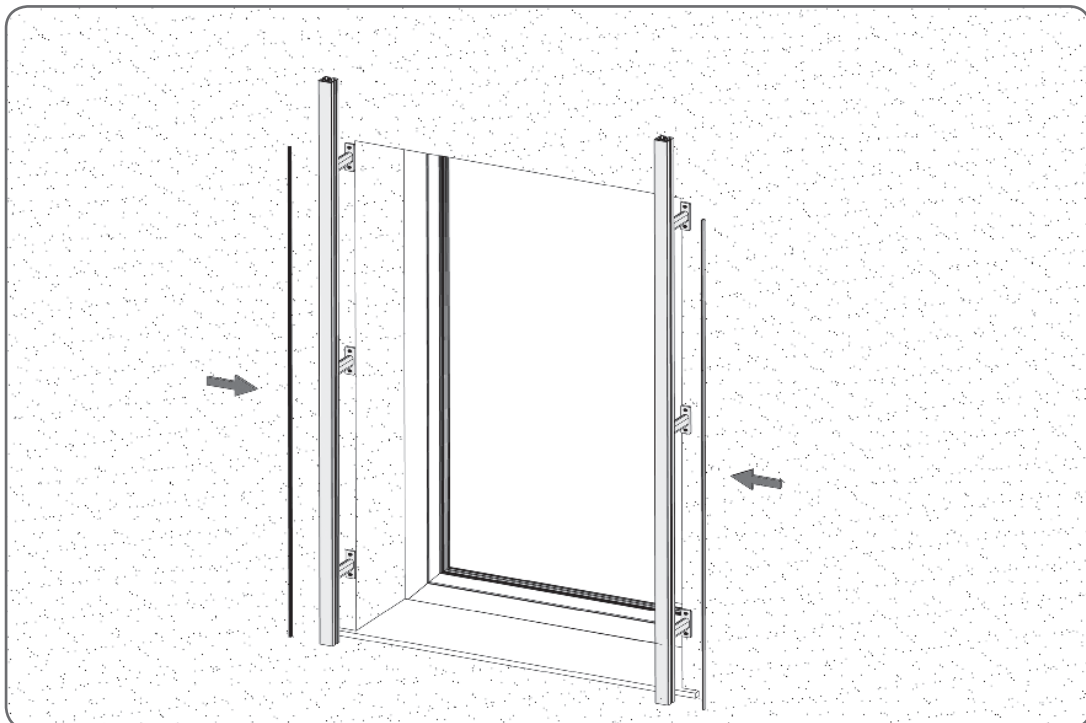
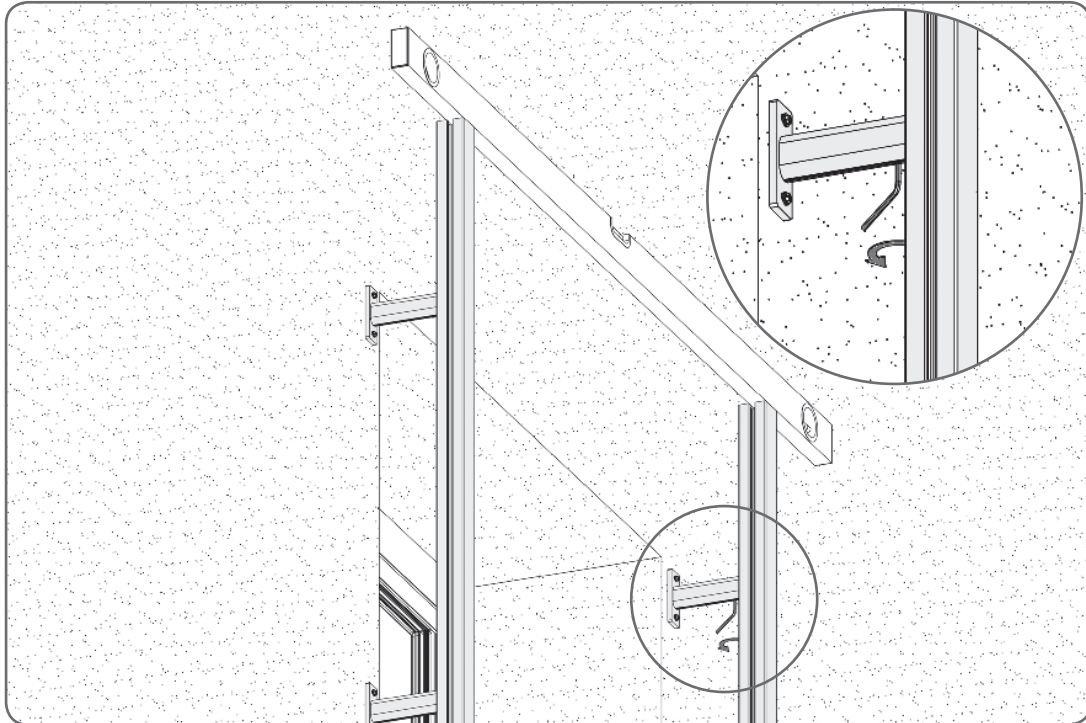



### 4.3. Installation of self-supporting guide channel handles

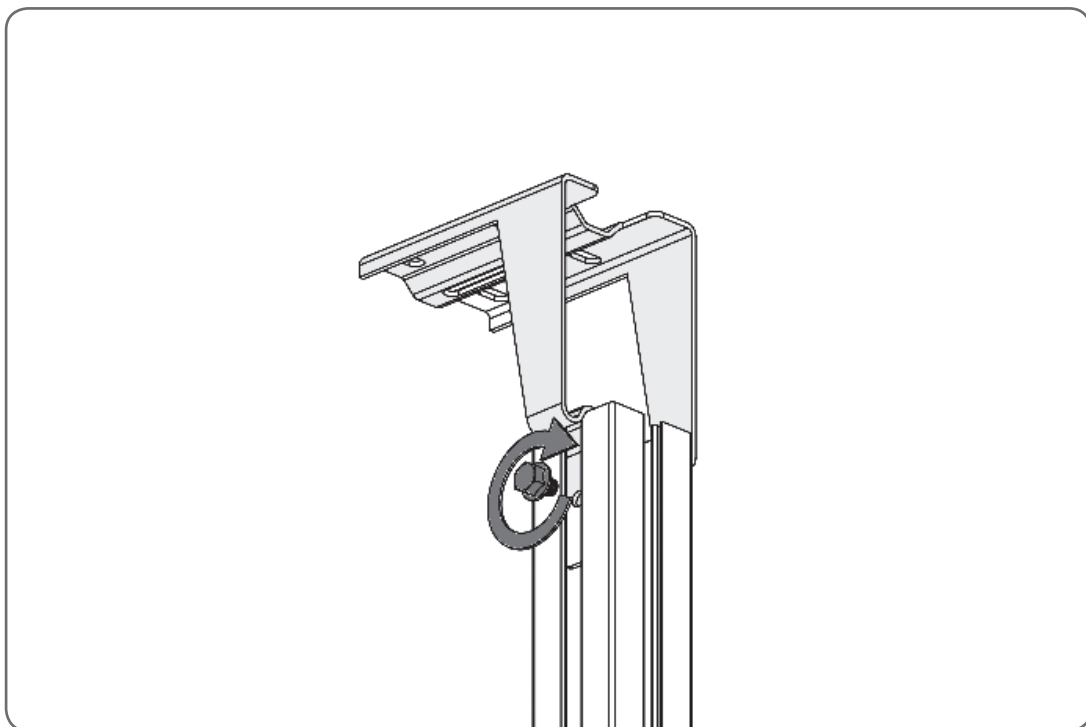
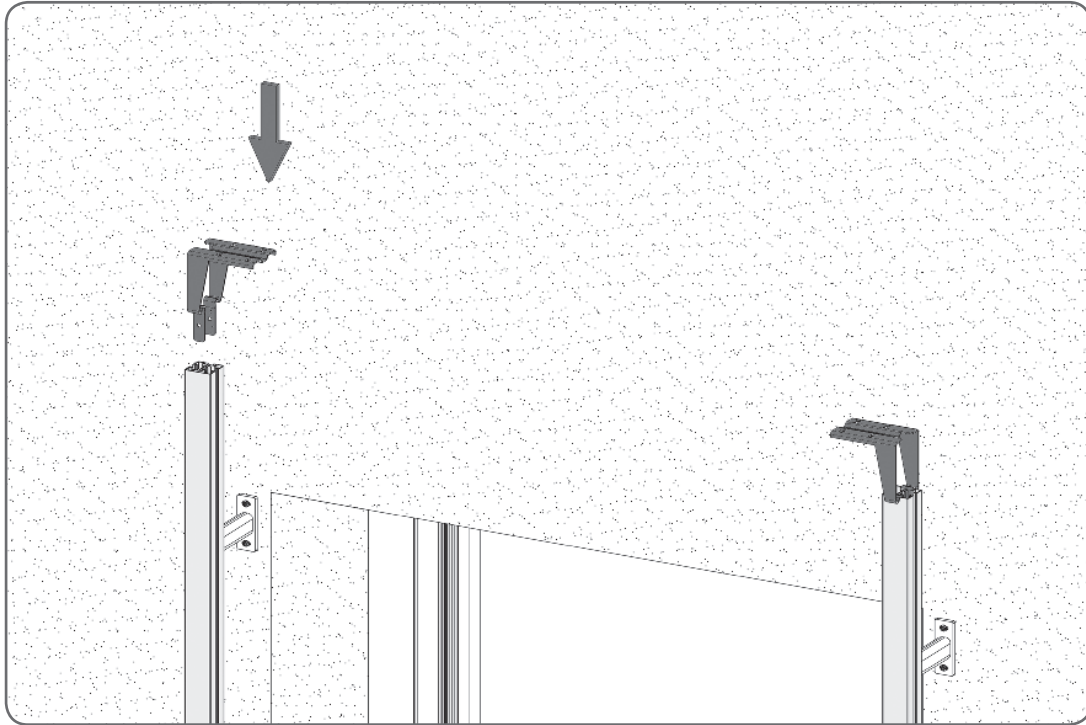

#### 4.4. Box assembly - part 1

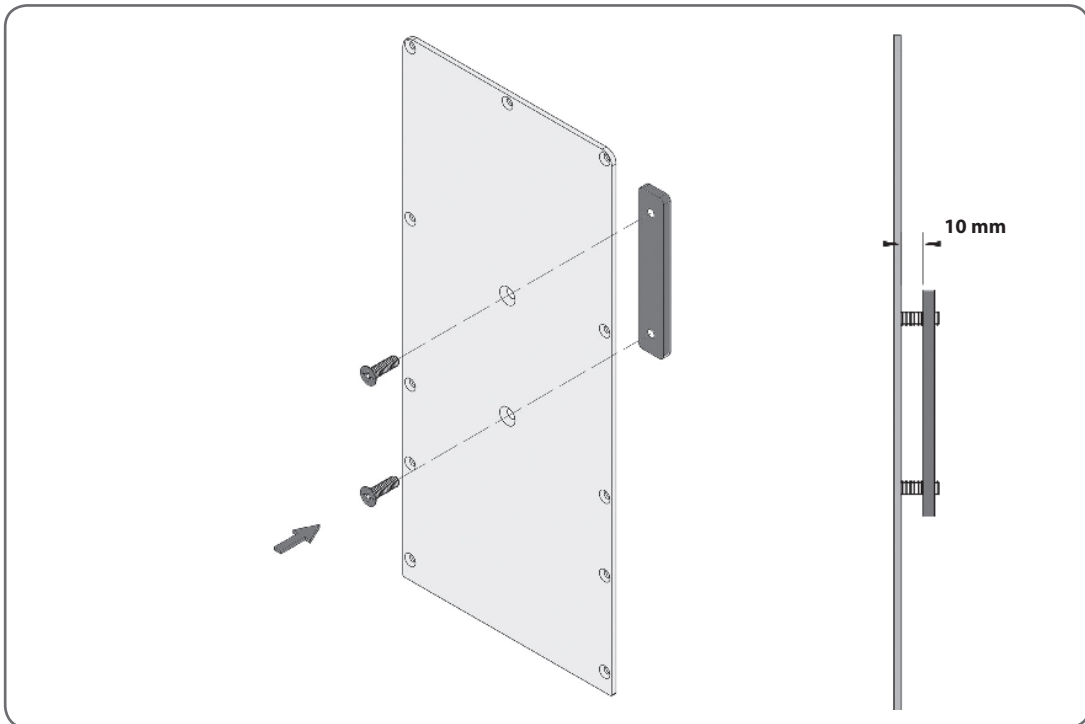
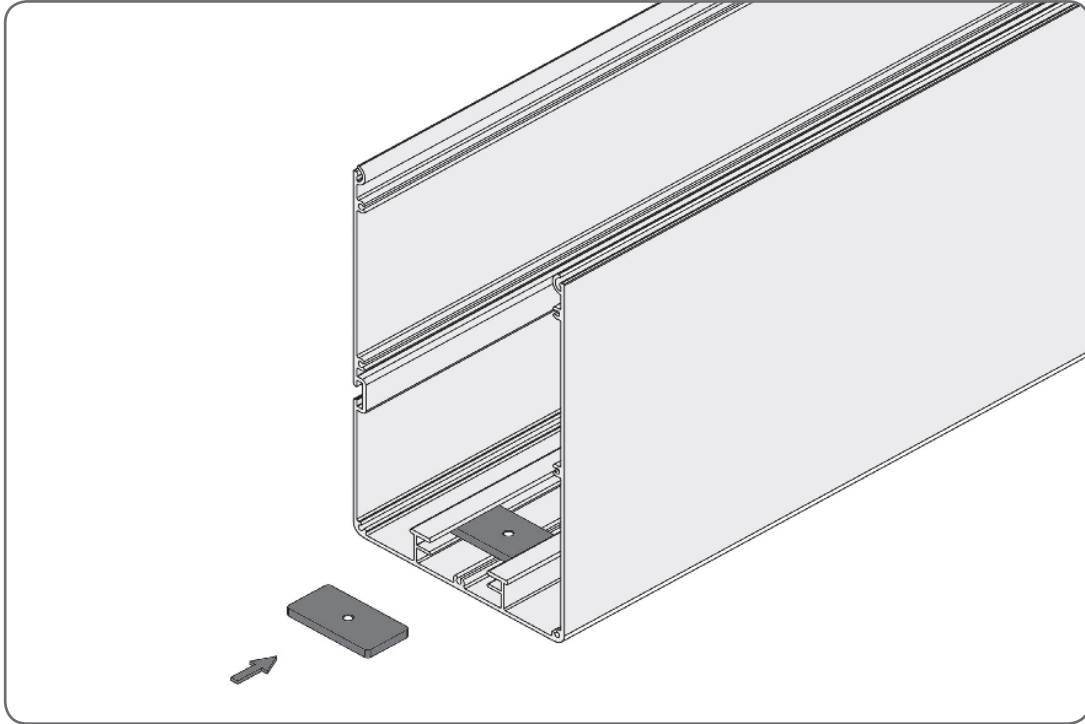

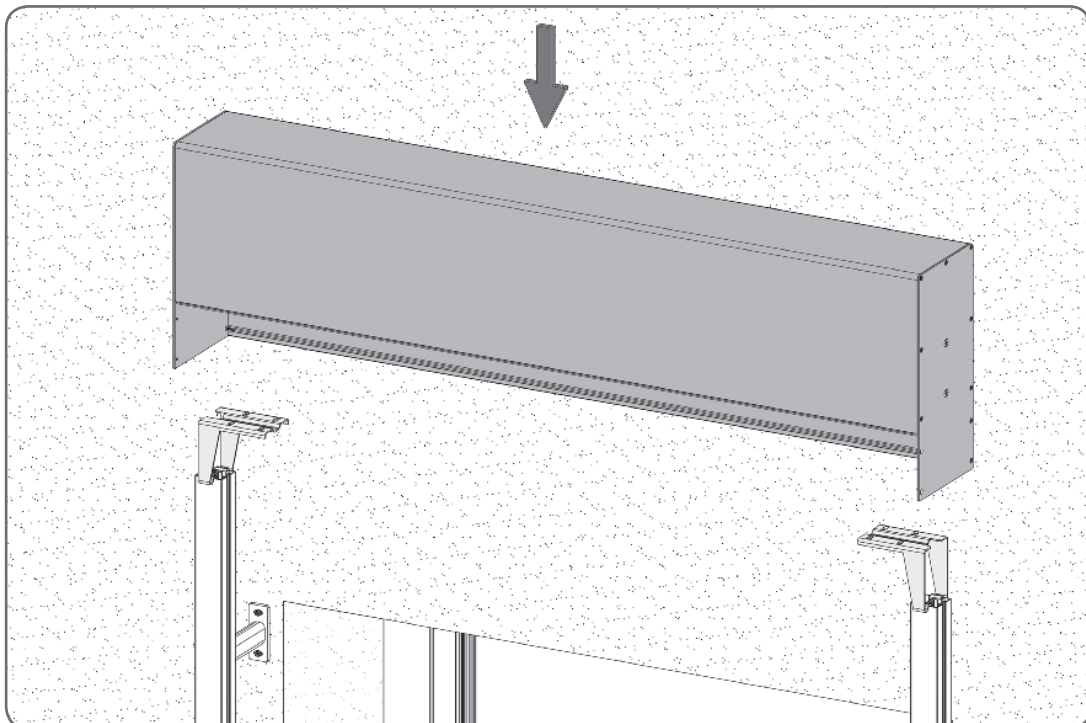
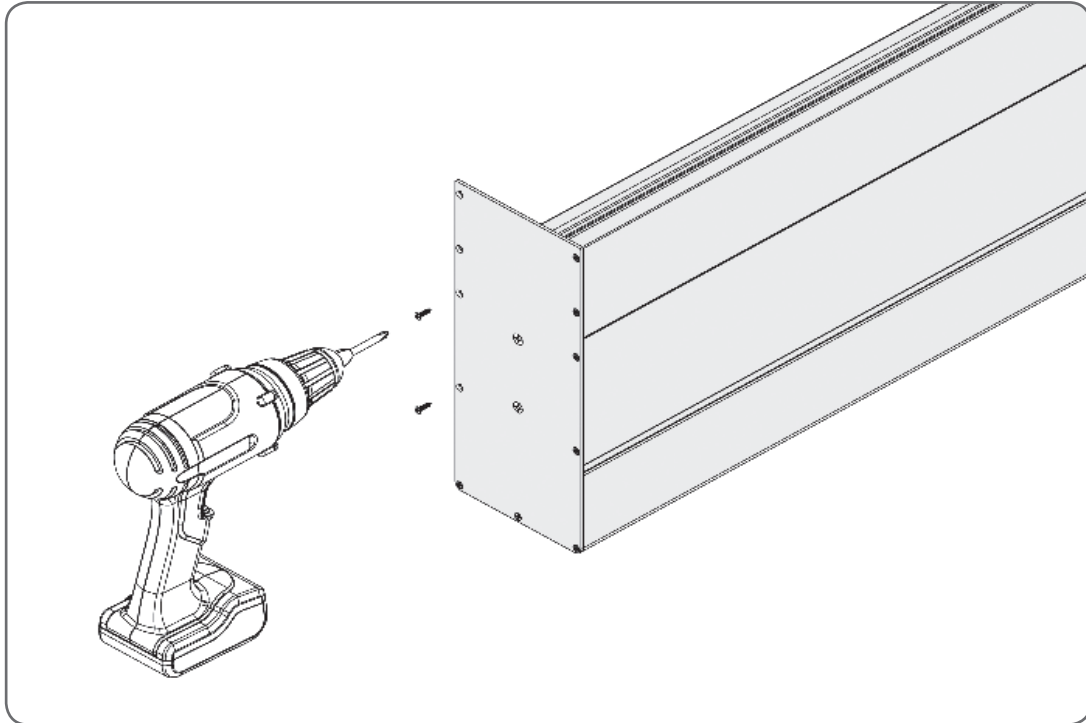

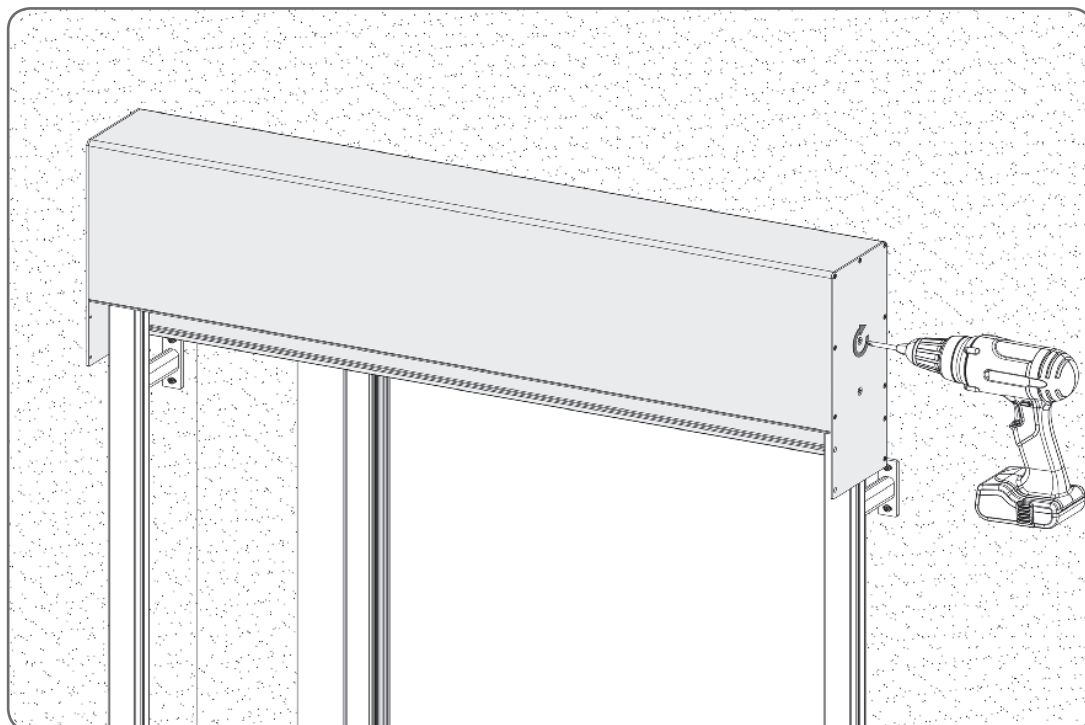
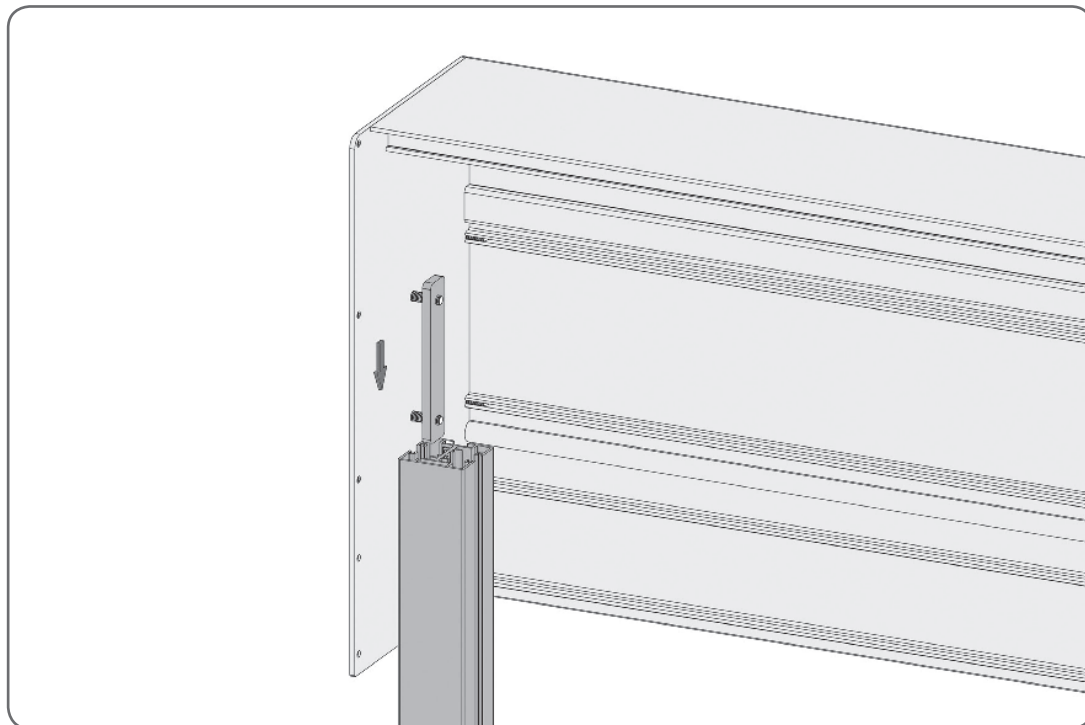

#### 4.4.1. Connecting boxes

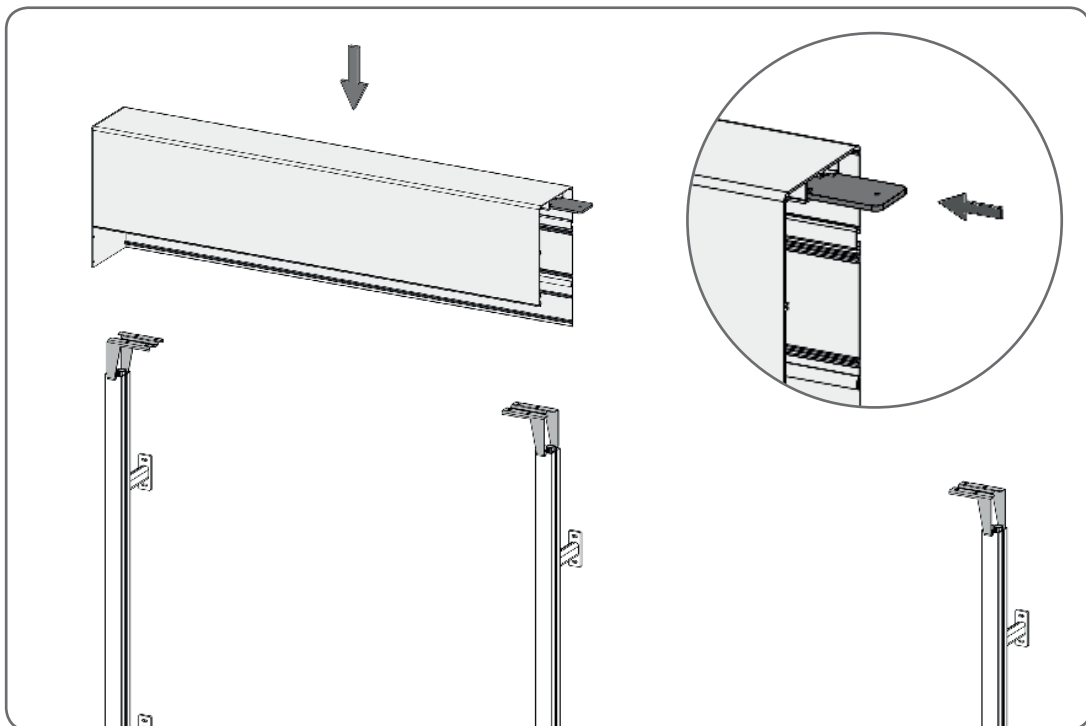
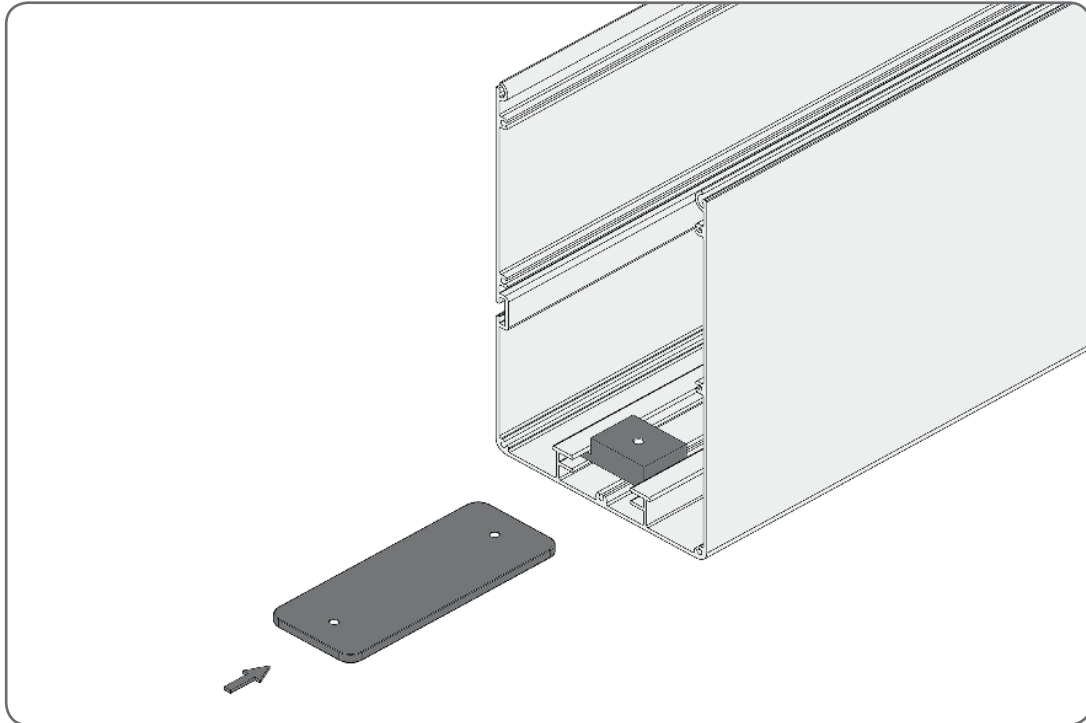

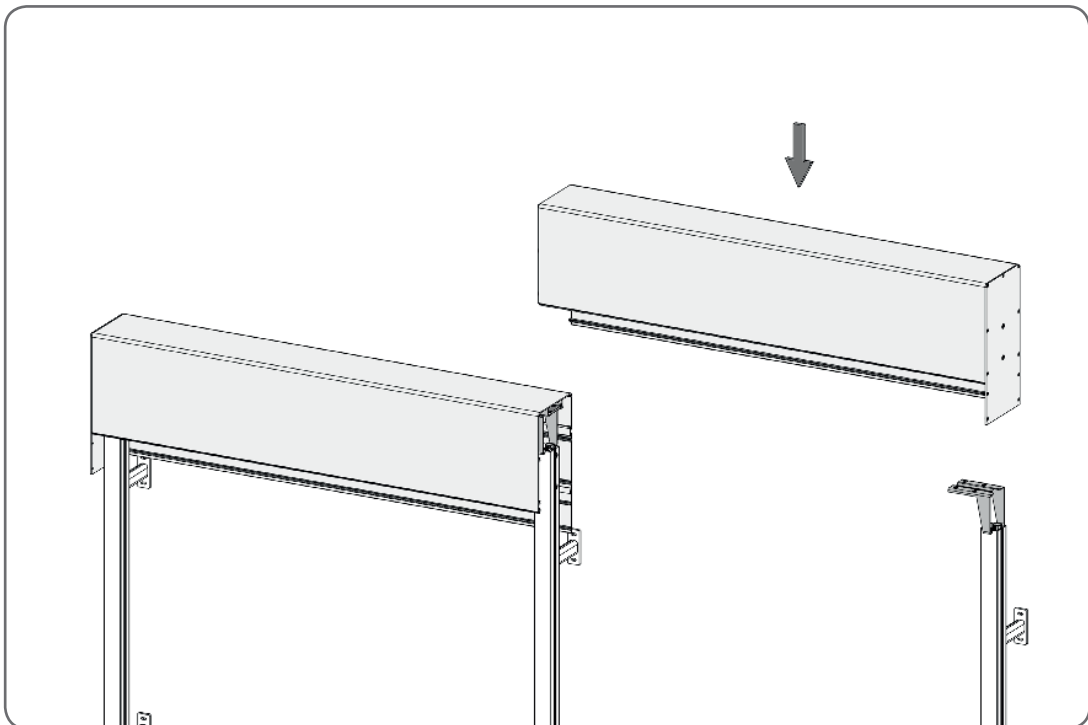
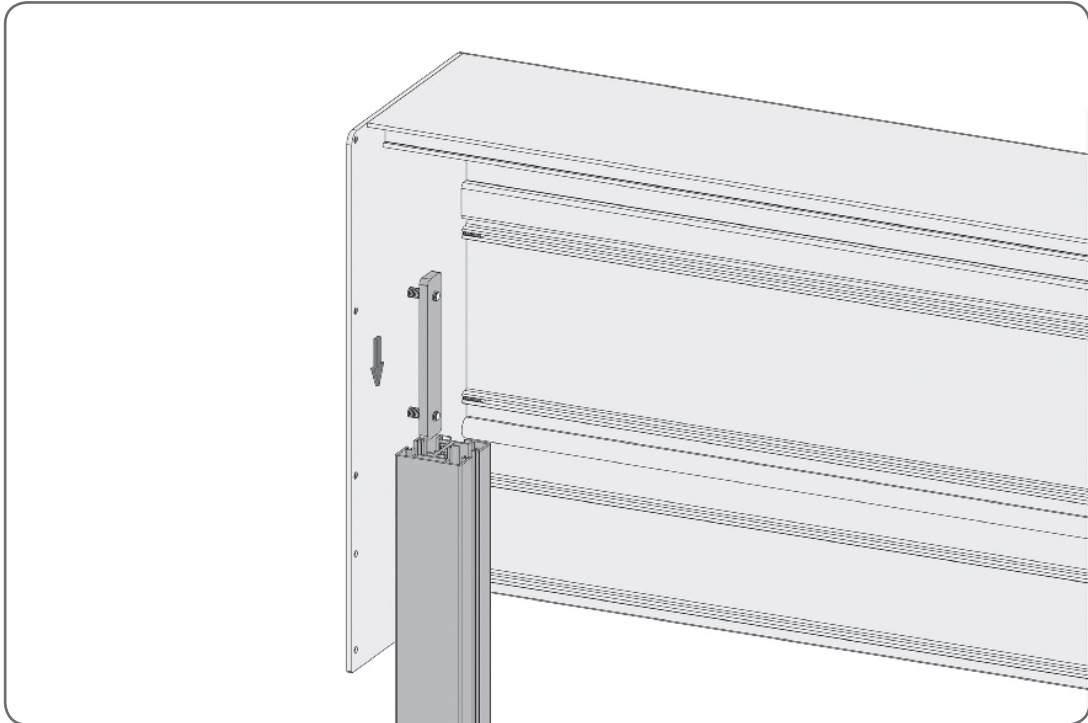



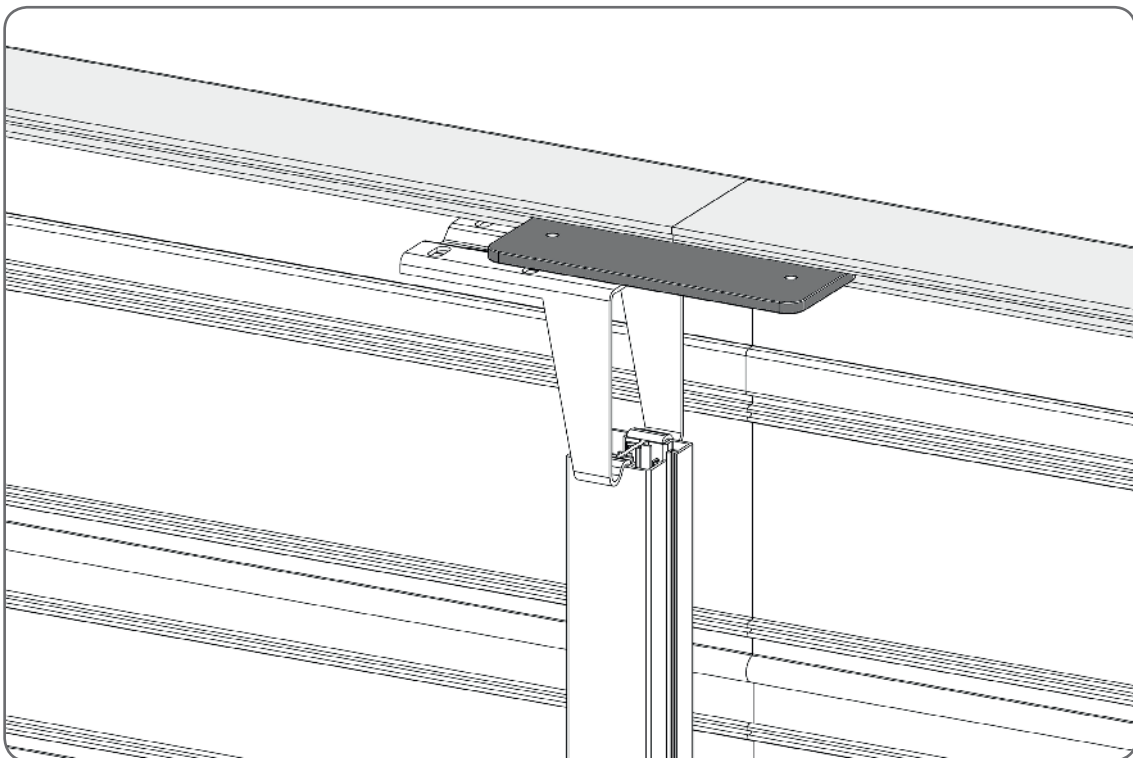
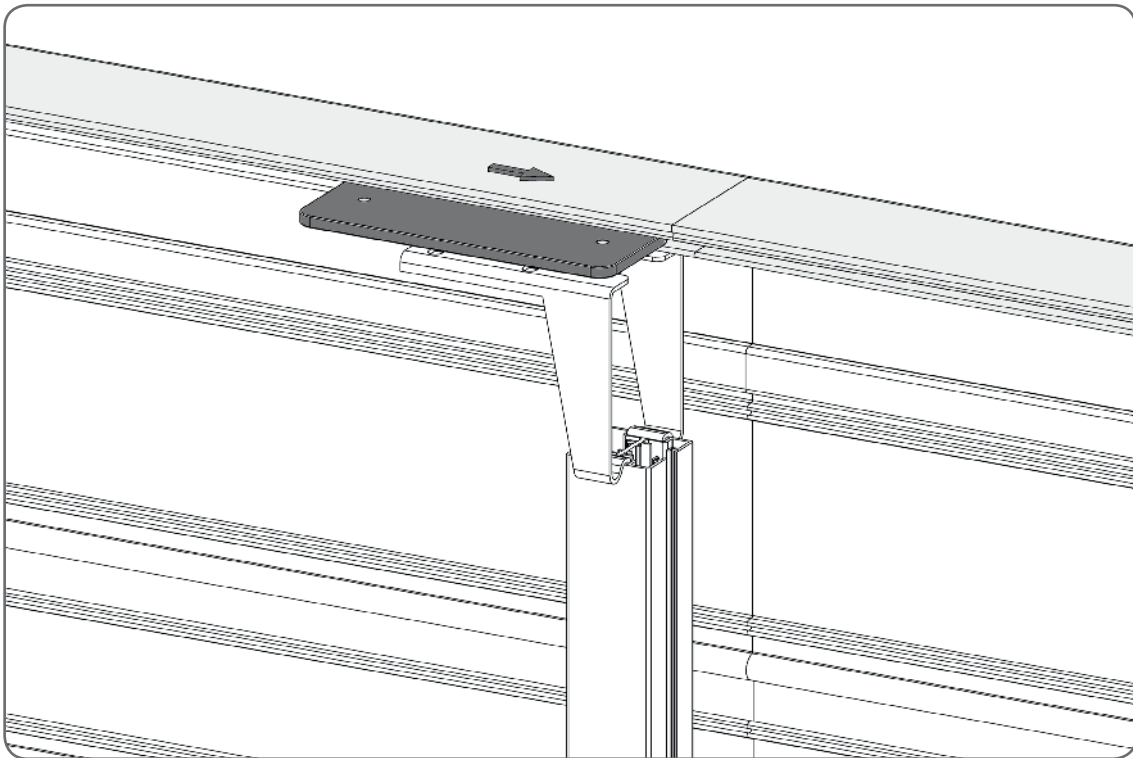

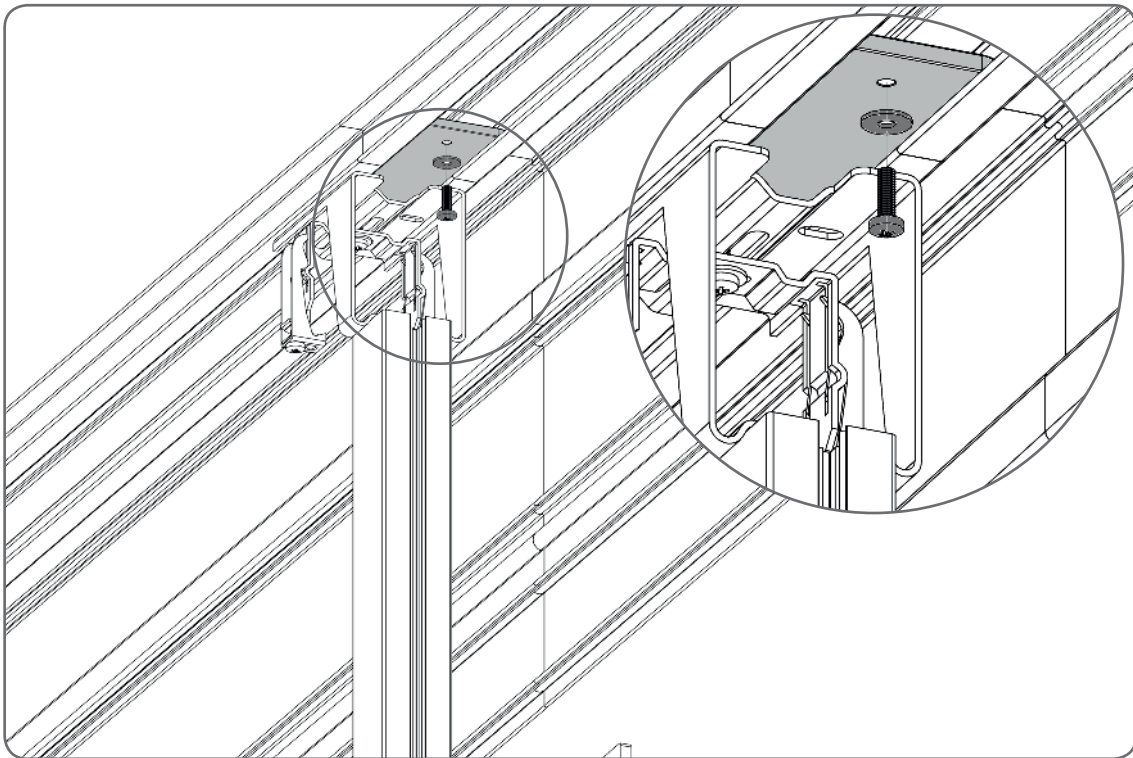
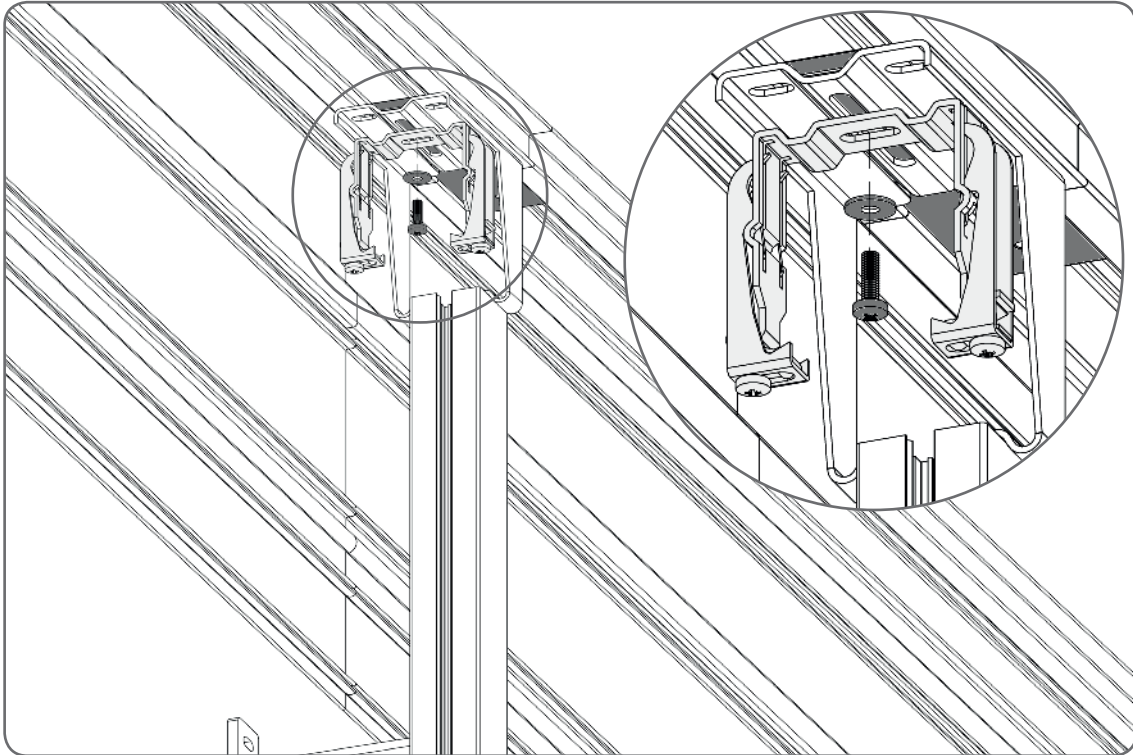

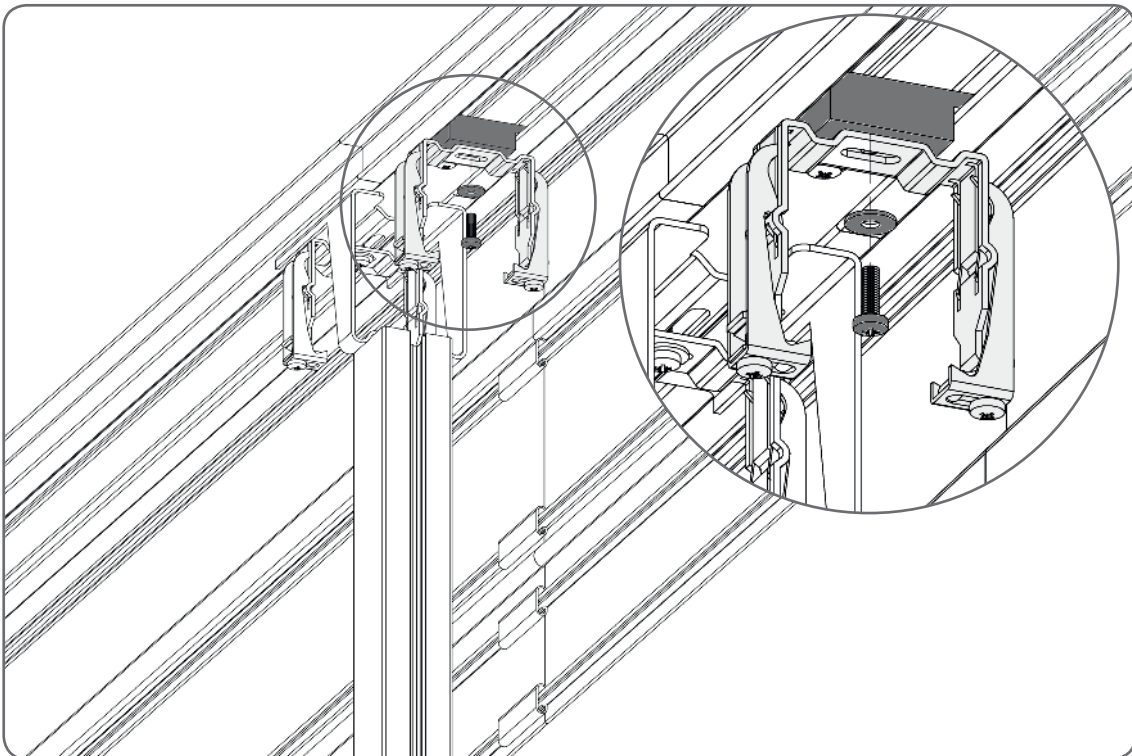
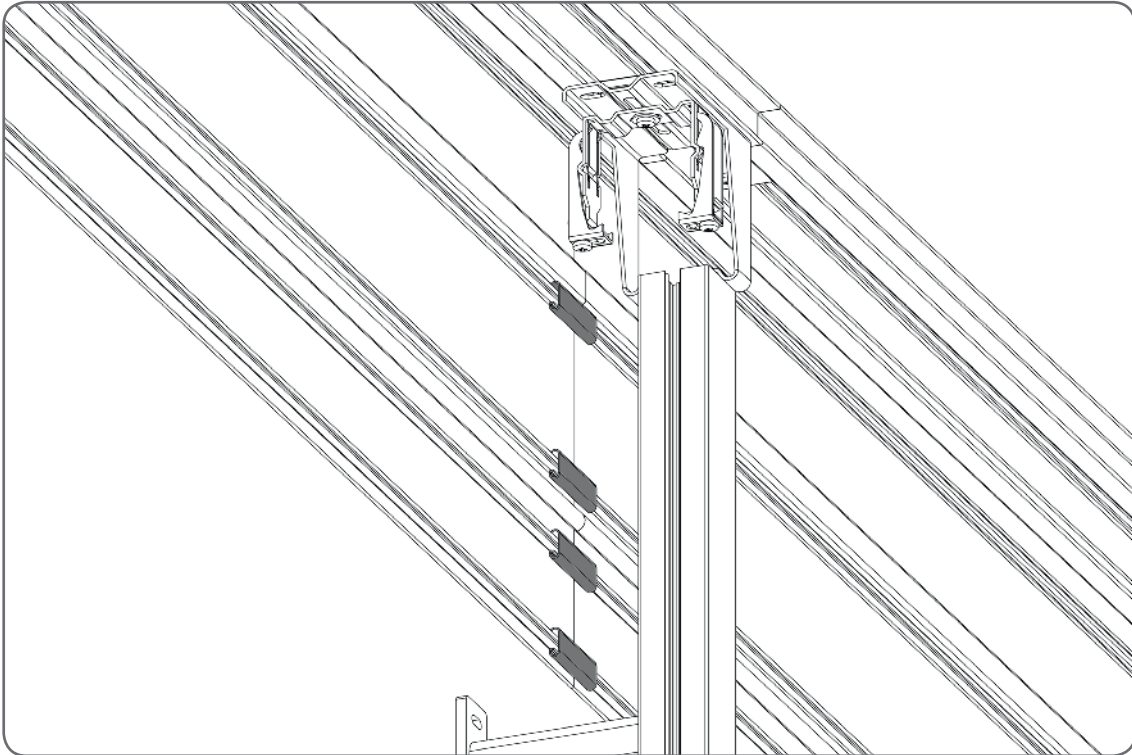

#### 4.5. Guide rail bracket installation

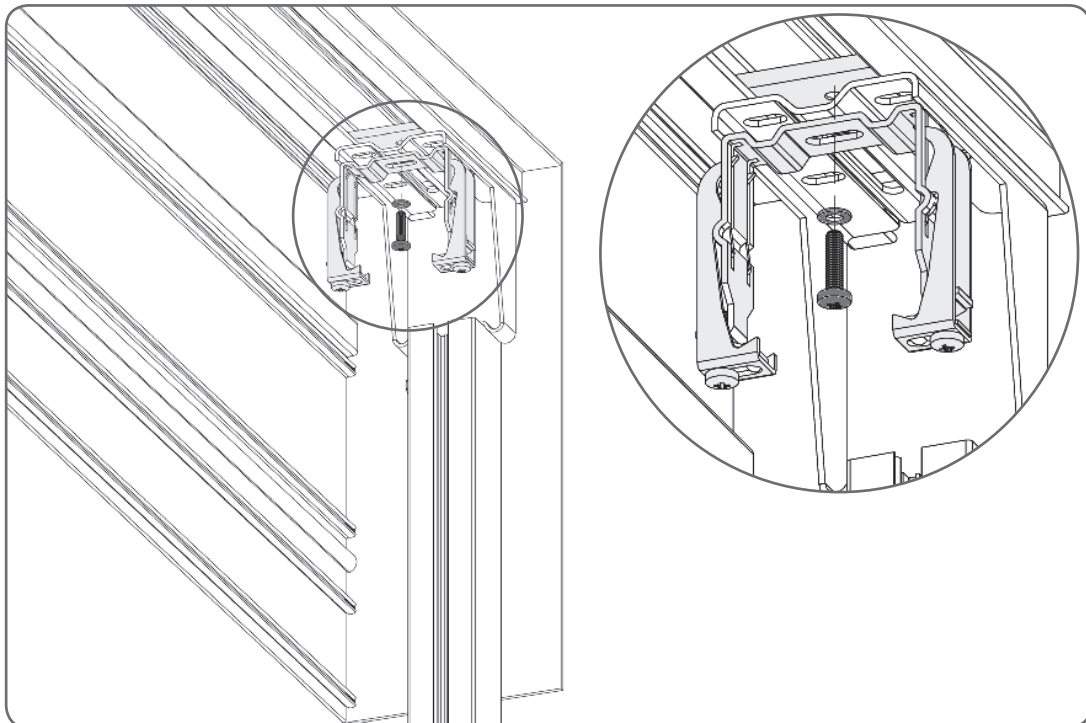
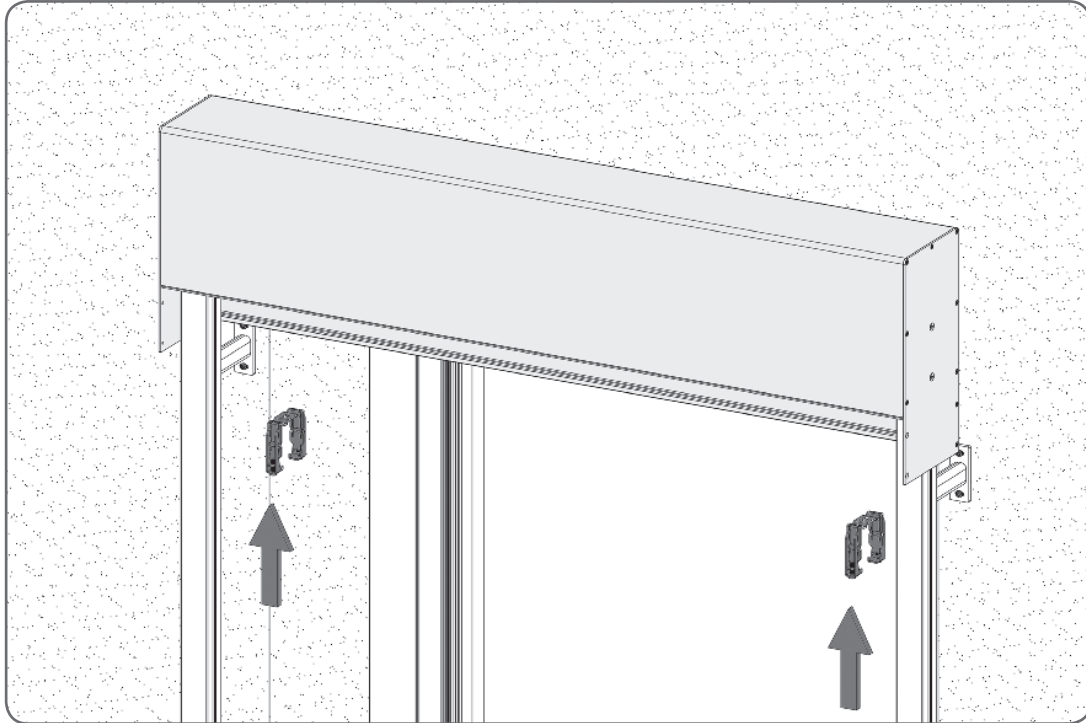



#### 4.6. Package installation

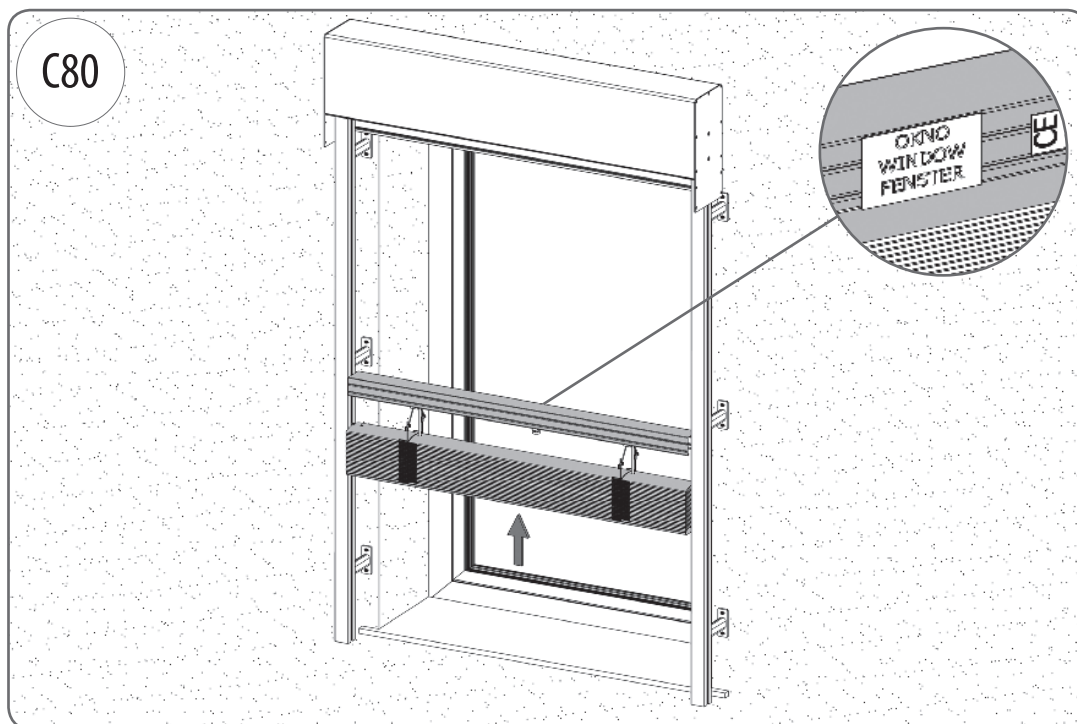

⚠ The package should be installed in such a way that the „WINDOW” sticker is on the window side.

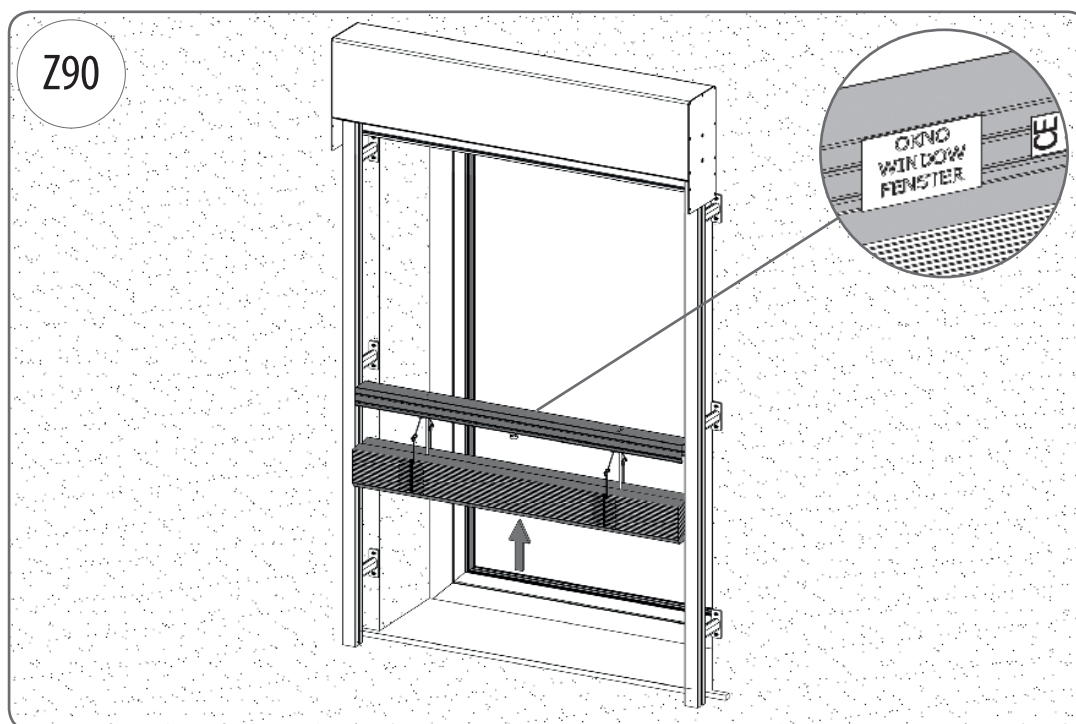

⚠ The package should be installed in such a way that the „WINDOW” sticker is on the window side.

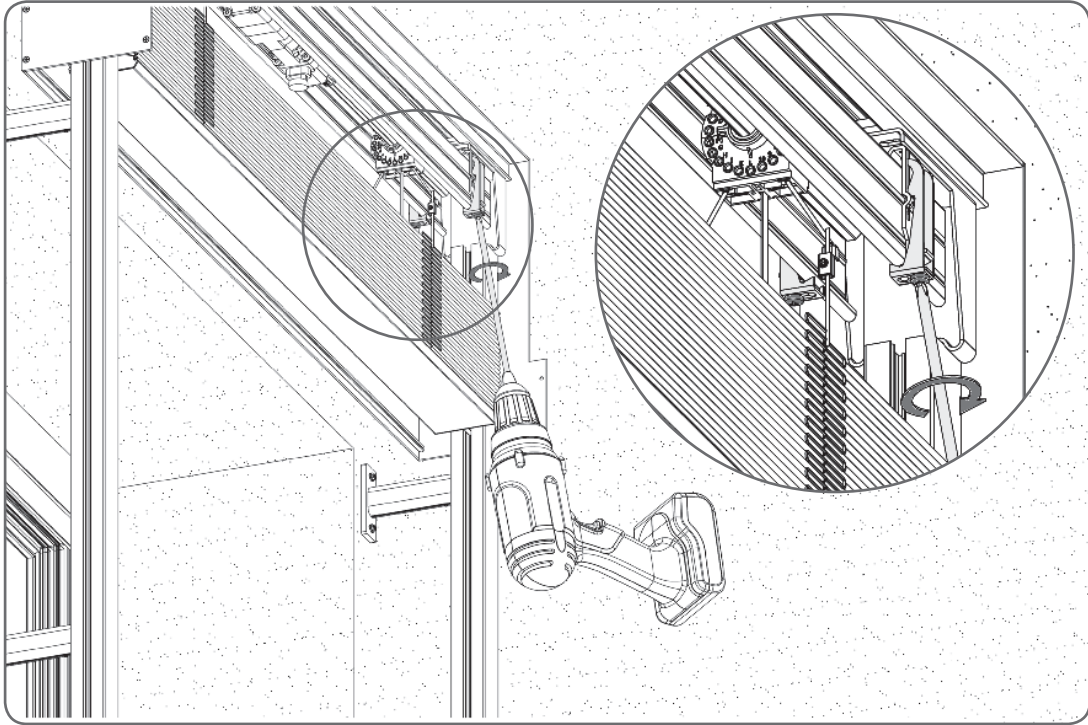

 *The package should be centered before screwing the handles.*

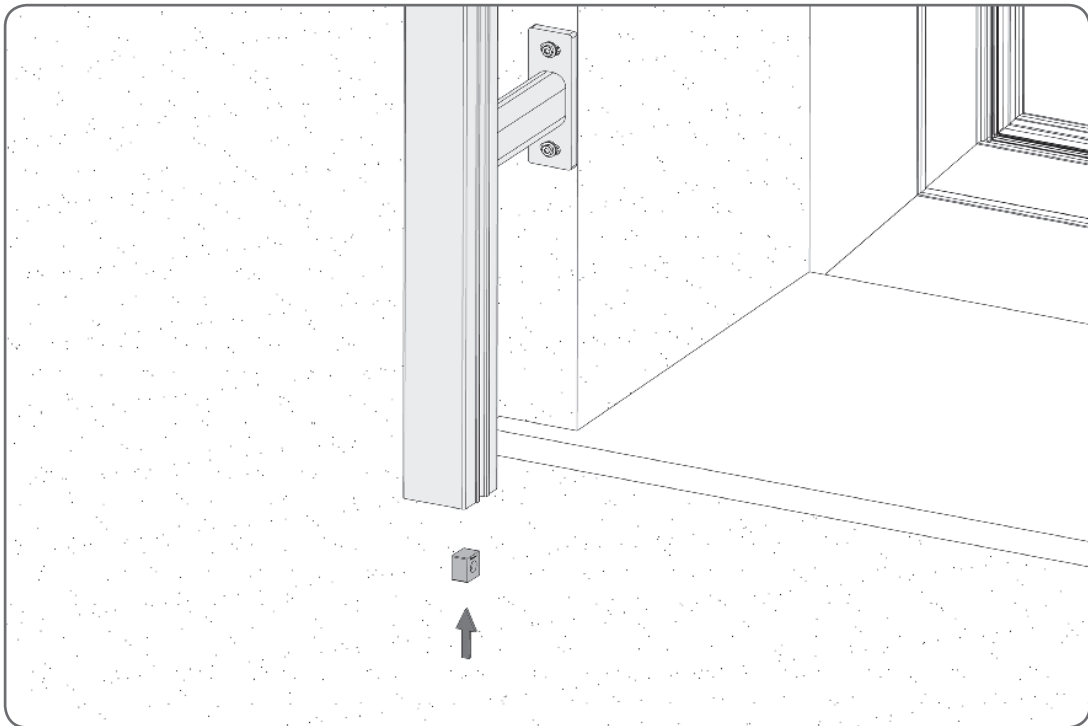



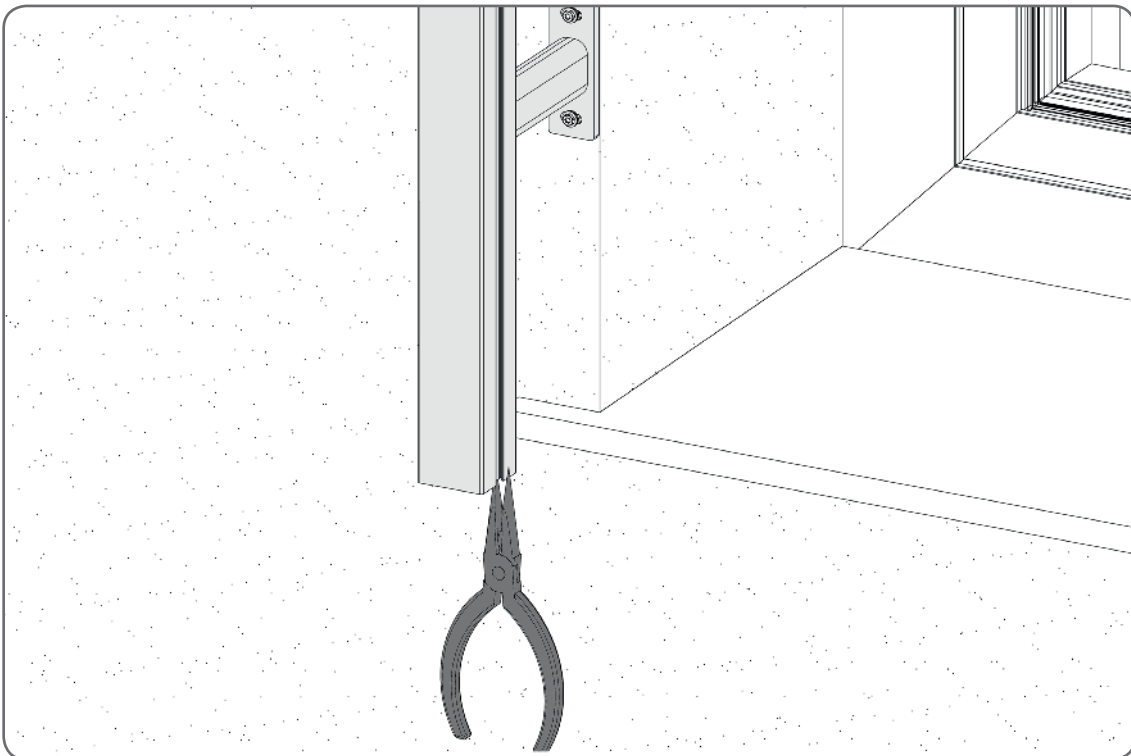
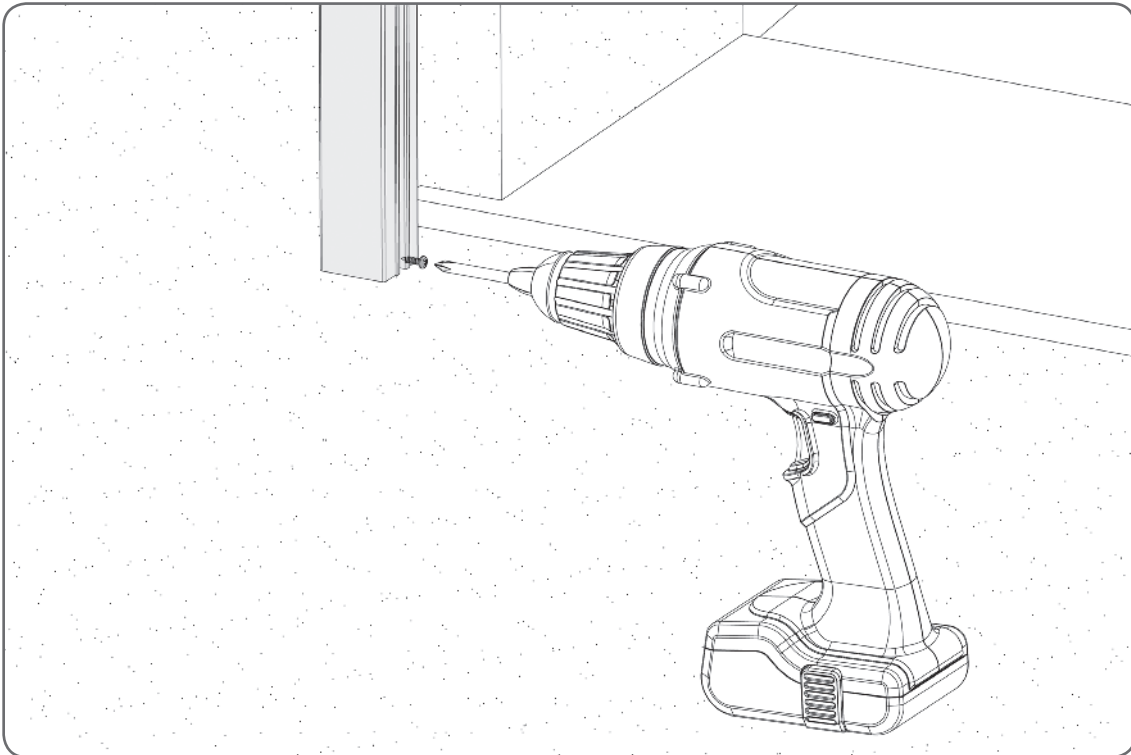

#### 4.7. Box assembly - part 2

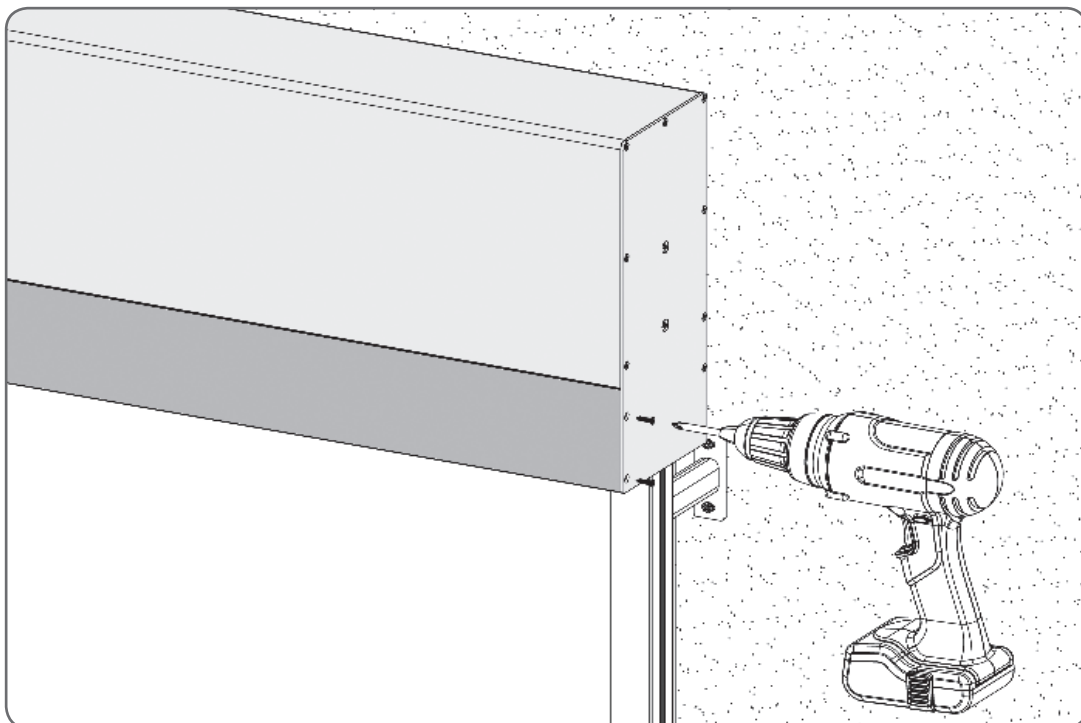
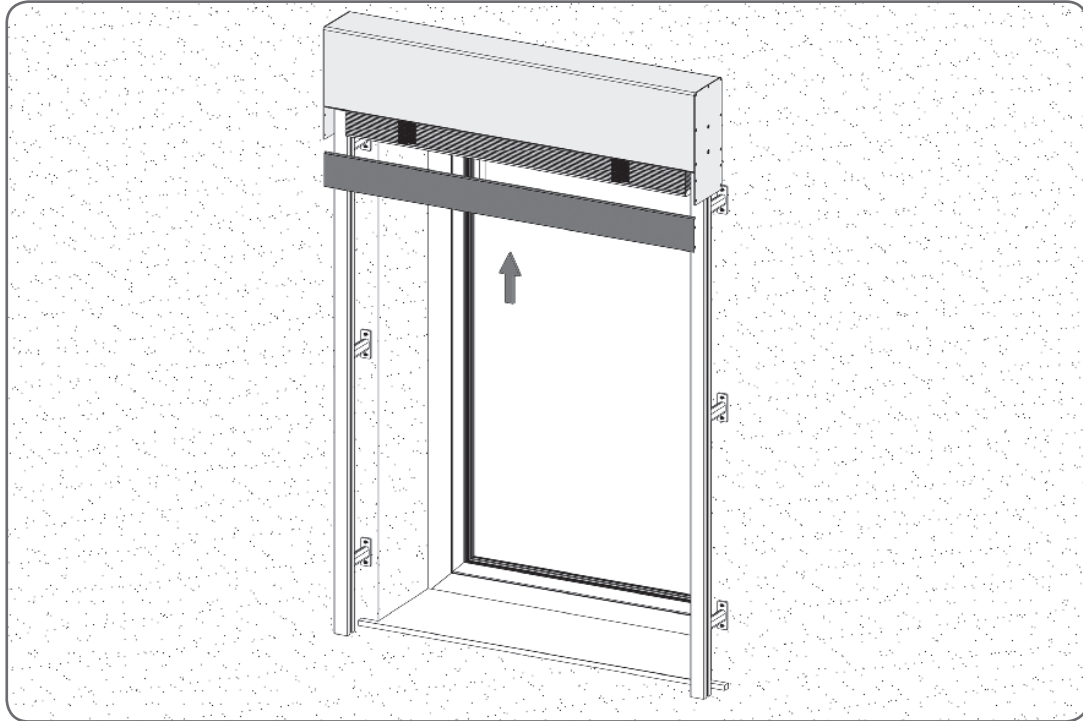

## 4.8. Starting

 Before starting the venetian blind motor must be connected according to the motor manufacturer instruction

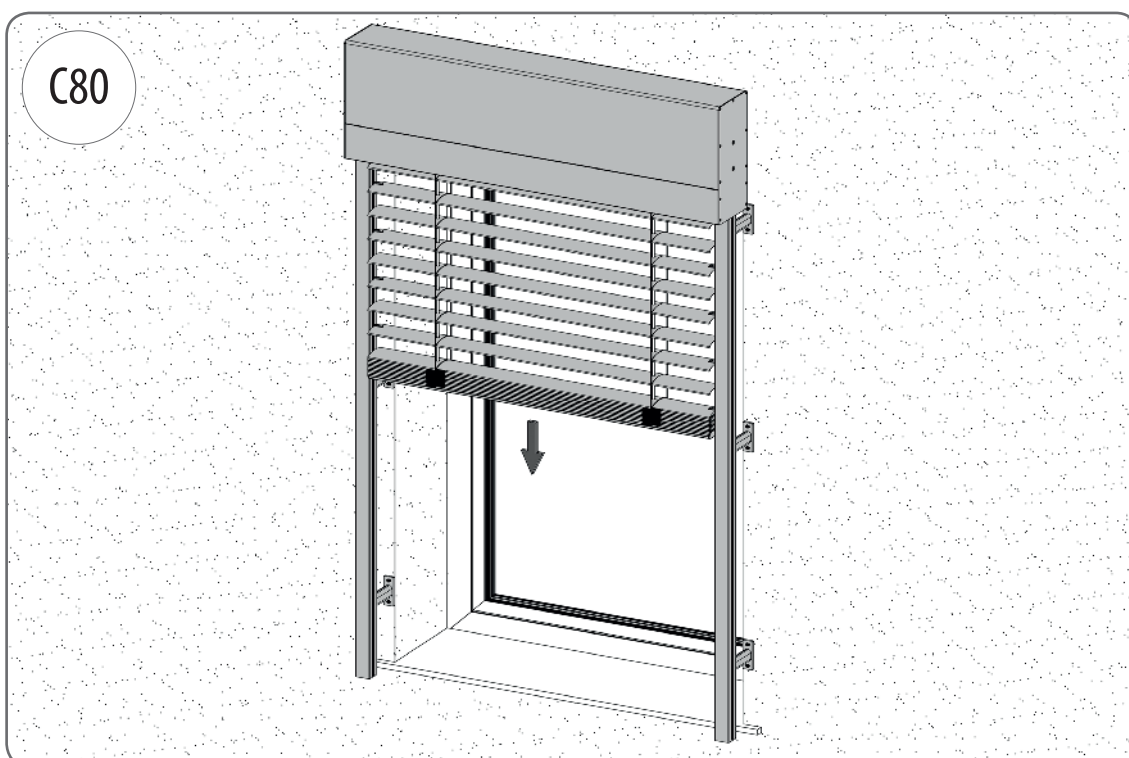
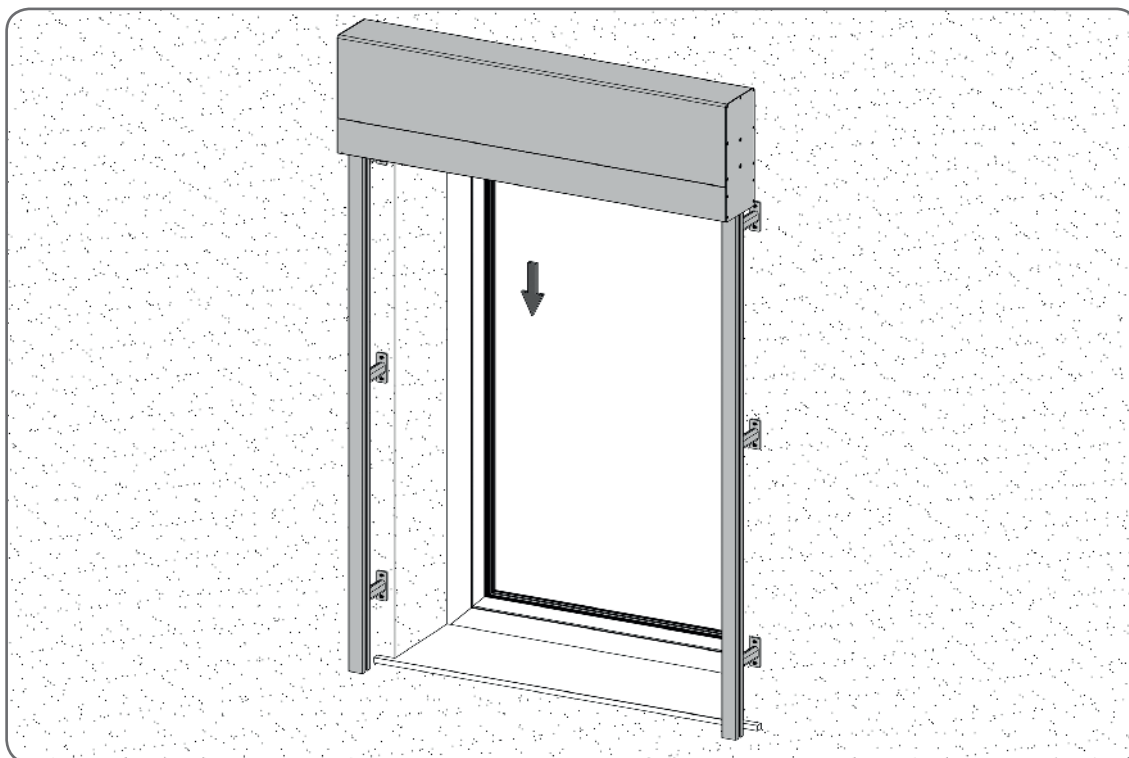

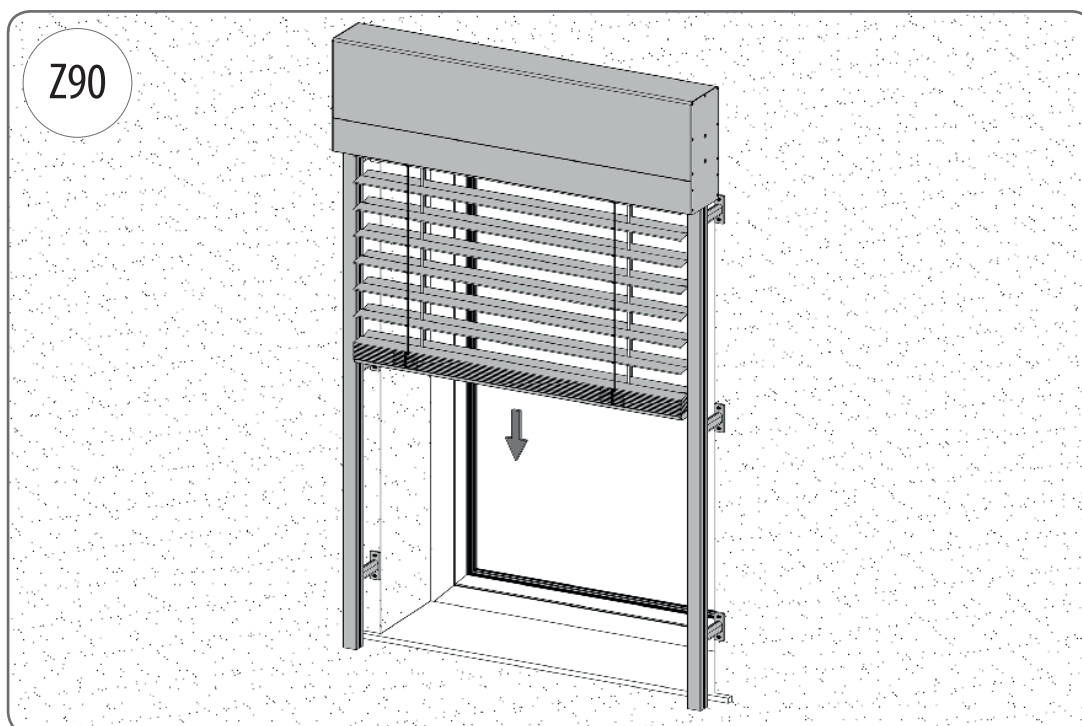
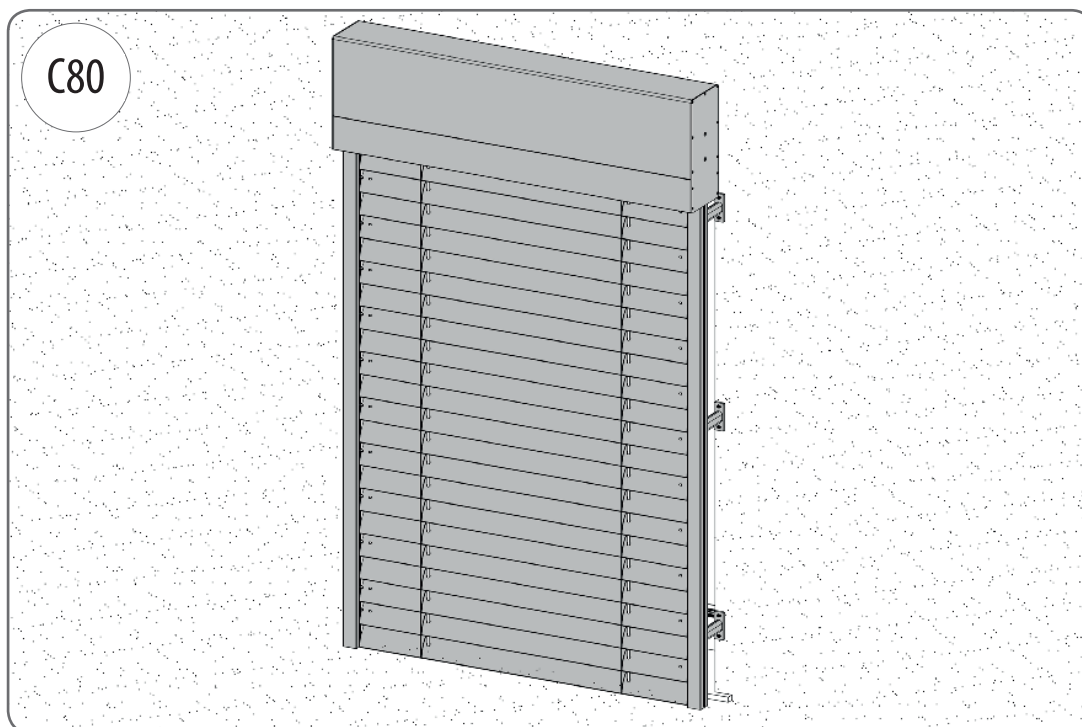

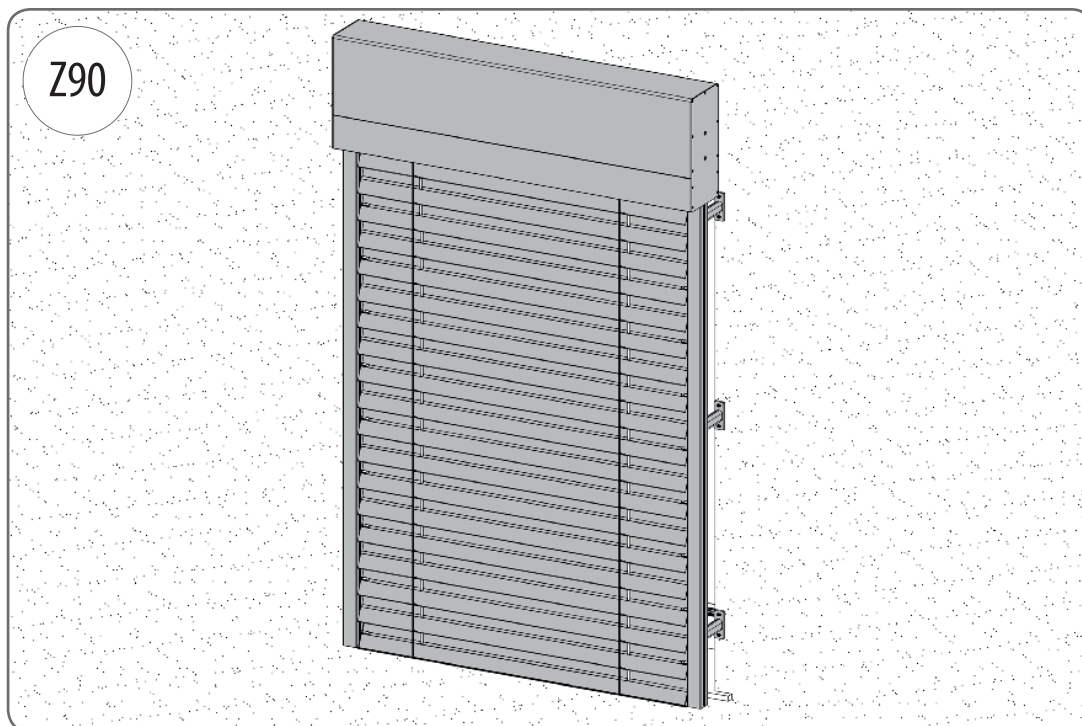



## 5. COMMENTS

### 5.1 Bottom rail level adjustment

If the bottom rail isn't level, perform the following steps.

1. Lower the venetian blind to the lower end position.
2. Check pin position in all mechanisms and if necessary, place them in a vertical position, then raise and lower the venetian blind again.

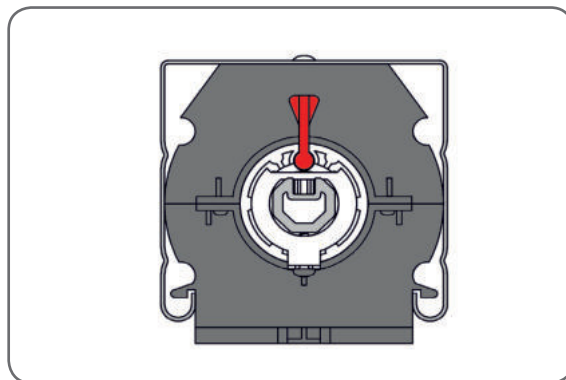
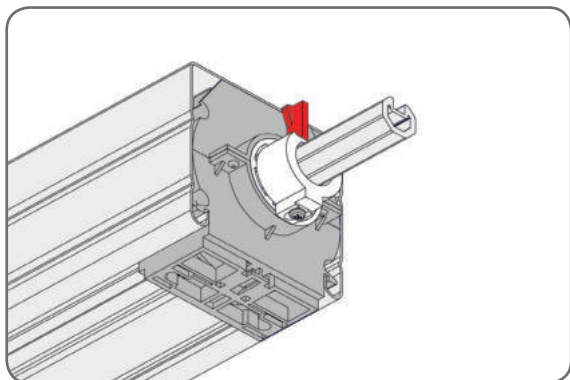

3. If the bottom rail is still not level, adjust it by changing setting of the pin in the mechanism to which the longest strap is attached.

